

DINGS'

Precision Motion Specialist

HYBRID ROTARY STEPPER MOTOR PRODUCT CATALOG

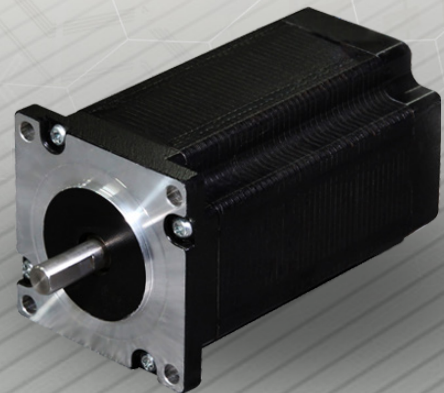
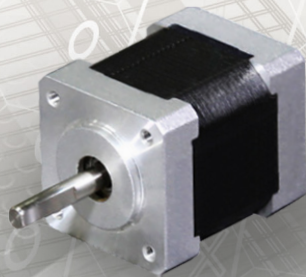
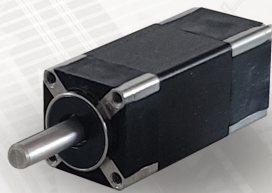

DINGS' provides 8 different sizes of hybrid stepper motors from 14mm to 86mm.

Each size has multiple stack lengths. Single or dual shaft is standard but customized shaft options are also available. DINGS' can customize all range of hybrid stepper motors as encoder ready for general motion solution providers and also encoder housing, special machining of front and rear shafts, special cables, wire harness assemblies and other solutions are available.

According to customer's requirements, we can adopt certain range of gearboxes, encoders, connectors and cables too. In addition, various ratio of planetary gearboxes, DINGS' standard encoders and power-off brakes, IP Protection is optional.



Hybrid Rotary Stepper

CONTENTS

Part number construction

Product overview

Size 6 · 14 mm

Size 8 · 20 mm

Size 11 · 28 mm

Size 14 · 35 mm

Size 17 · 42 mm

Size 23 · 57 mm

Size 24 · 60 mm

Size 34 · 86 mm

Accessories and options

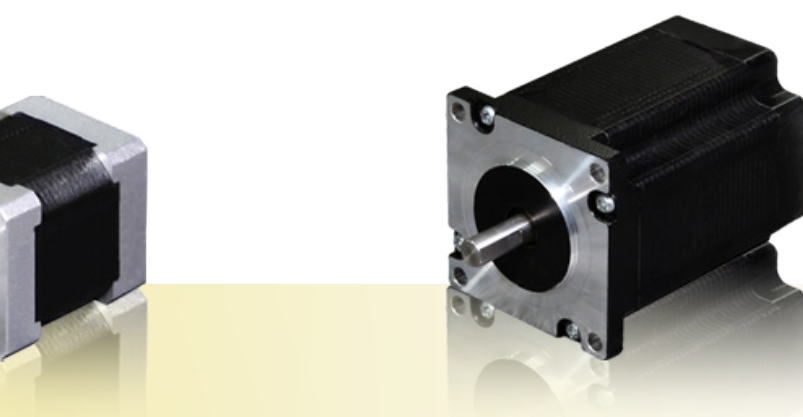

Motor

Part Number Construction

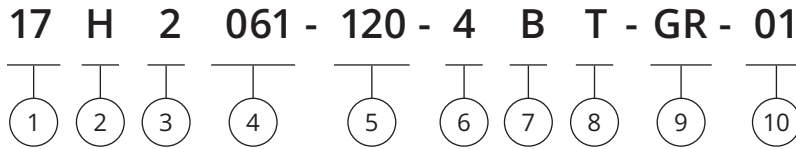

① Motor Size

Motor Size (mm)	14	20	28	35	42	57	60	86
Motor Size (NEMA)	6	8	11	14	17	23	24	34

② Basic Structure

H = Normal
P = IP54
W = Enhanced

*For IP65, please contact DINGS' for more information

③ Motor Step Angle (°)

1 = 3°
2 = 1.8°
3 = 1.2°
4 = 0.9°
5 = 0.72°
6 = 0.36°

④ Motor Length (mm)

⑤ Rated Current

XXX = Rated current ×100 (A)

⑥ Wiring Number (3,4,5,6,8)

⑦ Shaft Configuration

A = Single shaft
B = Dual shaft

* Shaft dimension and D-Cut customization, please contact DINGS'

⑧ Wiring Method

L = Flying lead wire
T = Integrated connector
C = Cable

* If customer has special requirement for connector and cable, please inform DINGS'

⑨ Option

GR = Planetary gearbox ready
BR = Brake ready
ER = Encoder ready
PG = Planetary gearbox
Refers to the part number of gearbox with ratio
DG = DINGS' gearbox
FB = Power off brake, NB = Power on brake
EKX = Encoder [X = Encoder Resolution]

*DINGS' can customize shafts and covers to be ready to assemble Gearbox, Brake or Encoder by customers, according to customer's requirements by drawing.

*DINGS' has standard planetary gearbox options. Please see product details.

*Power-Off Brake is available for Motor size 28, 35, 42, 57 and 60mm

⑩ Customer Sequence Number

Example

Naming code	17H2061-120-4BT-GR-01
Description	Size 42 mm Normal structure Step angle 1.8° Motor body length 61 mm Rated current 1.2 A 4 wiring leads Dual shaft Wiring method integrated connector Gearbox ready Customization sequence code 01

Product Overview

Part Number	Current (A _{RMS})	Resistance (Ω)	Inductance (mH)	Holding Torque (N·m)	Rotor Inertia (g·cm ²)	Motor Length (mm)	Mass (g)
6H2030	0.3	23	4.5	0.005	1.5	32	35
8H2028	0.5	5.1	1.5	0.014	2.7	27	60
8H2038	0.5	8.8	2.7	0.02	3.3	38.2	80
11H2033	1	2.1	1.2	0.06	9	33.5	110
11H2045	1	4.1	3.2	0.1	13	45	200
11H2052	1	4.7	3.9	0.14	18	52	280
14H2027	0.5	9.2	7.4	0.1	12	27	150
14H2037	1.5	1.65	2.1	0.2	20	37	210
14H2052	1.5	2.65	4.1	0.4	35	52	250
17H2031	1.2	1.7	2.3	0.16	23	31	200
17H2034	1.2	2.1	2.7	0.25	25	34	230
17H2041	1.2	2.4	4.7	0.4	54	41	300
17H2049	2	1.3	2	0.48	77	49	360
17H2061	2	1.7	3.6	0.72	110	61	500
23H2042	1	4.2	9	0.6	140	42	460
23H2045	1	4.5	12	0.8	180	45	520
23H2051	2	1.5	4.4	1	240	51	640
23H2055	2	1.6	5.2	1.2	280	55	720
23H2065	3	0.9	2.7	1.6	350	65	860
23H2076	4	0.6	2.4	2	480	76	1060
23H2100	5	0.46	2.3	3	720	100	1500
24H2047	2	1.5	3.4	1	240	47	600
24H2056	3	0.8	2.3	1.5	340	56	800
24H2068	4	0.6	1.9	2.1	490	68	1000
24H2085	5	0.4	1.8	3	690	85	1300
34H2060	3	1	6	3	1100	60.5	1600
34H2075	4.5	0.6	4.2	4.5	1800	75	2100
34H2098	6	0.5	4	7	2800	96.5	2900

Size 6 (14mm) Series

The size 6 [14mm] which is smallest hybrid rotary stepper motor from DINGS' has Max. 0.005N·m of holding torque.

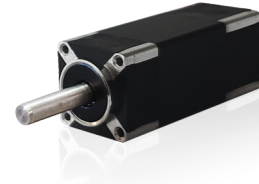

Parameters

General							
Accuracy	Step angle		1.8°±5%				
	Resistance		±10% / 20 C				
	Inductance		±20% / 1KHz				
Insulation class			B				
Duty type			S1				
Dielectrical strength			250 VAC / 1 KHz / 1 mA / 1 s				
Insulation resistance			100 MΩ / 500 VDC				
Permissible radial load (5mm distance from mounting surface)		Permissible radial load (10mm distance from mounting surface)		Permissible radial load (15mm distance from mounting surface)		Permissible radial load (20mm distance from mounting surface)	
15N		12N		8N		6N	
Parameter							
Type	Current (A [RMS])	Resistance (Ω)	Inductance (mH)	Holding Torque (N·m)	Rotor Inertia (g·cm ²)	Length (mm)	Mass (g)
6H2030	0.3	23	4.5	0.005	1.5	32	35
Material							
End bell			Aluminum alloy				
Bearing			Deep groove ball bearing				
Magnet			Sintered NdFeb				
Shaft			Stainless steel				
Wiring			UL 3135,30 AWG				

Dimensional Drawings

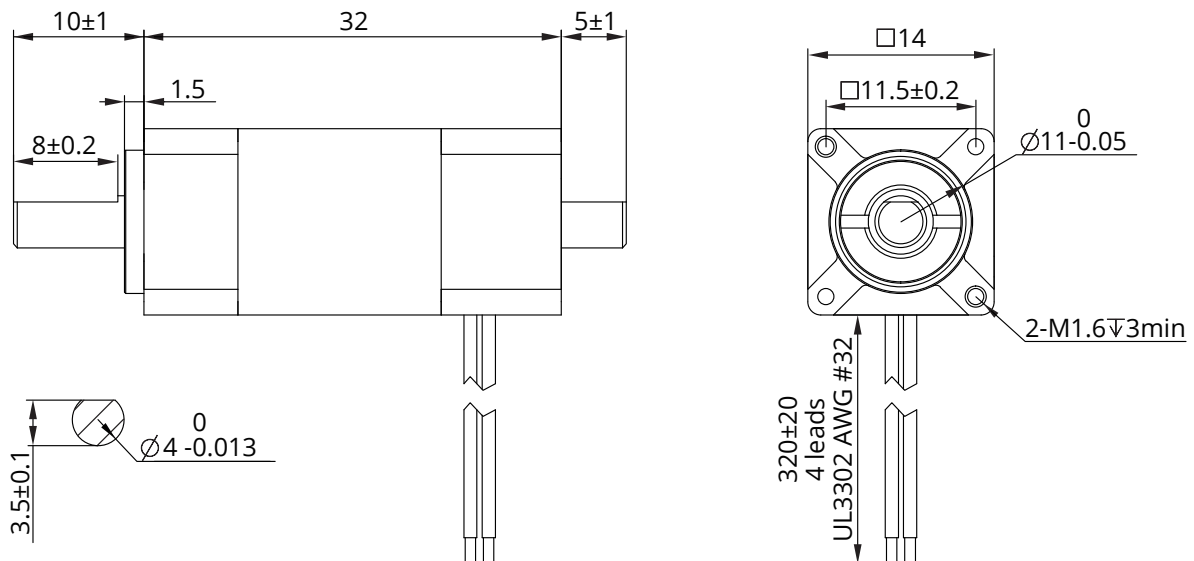

Size 6 (14mm) Series

Torque Performance Curves

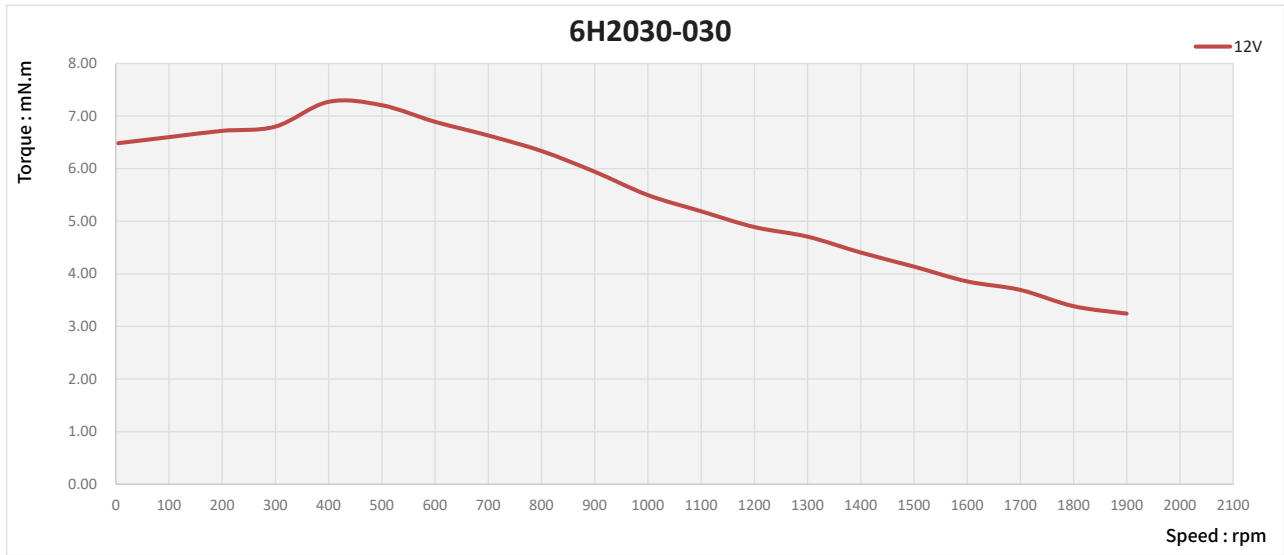

Size 8 (20mm) Series

The size 8 [20mm] Hybrid Rotary Stepper Motor has Max. 0.02N·m of holding torque. Encoders and 22mm frame planetary gearbox solutions are available. For special windings or customization, Please contact DINGS' for further information.

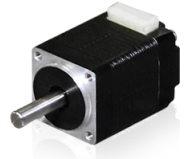

Parameters

General							
Accuracy	Step angle		1.8°±5%				
	Resistance		±10% / 20 C				
	Inductance		±20% / 1KHz				
Insulation class			B				
Duty type			S1				
Dielectrical strength			500 VAC / 1 KHz / 1 mA / 1 s				
Insulation resistance			100 MΩ / 500 VDC				
Permissible radial load (5mm distance from mounting surface)		Permissible radial load (10mm distance from mounting surface)		Permissible radial load (15mm distance from mounting surface)		Permissible radial load (20mm distance from mounting surface)	
15N		12N		8N		6N	
Parameter							
Type	Current (A _{RMS})	Resistance (Ω)	Inductance (mH)	Holding Torque (N·m)	Rotor Inertia (g·cm ²)	Length (mm)	Mass (g)
8H2028	0.5	5.1	1.5	0.014	2.7	27	60
8H2038	0.5	8.8	2.7	0.02	3.3	38.2	80
Material							
End bell			Aluminum alloy				
Bearing			Deep groove ball bearing				
Magnet			Sintered NdFeb				
Shaft			Stainless steel				
Wiring			UL 3265, 28AWG				

Dimensional Drawings

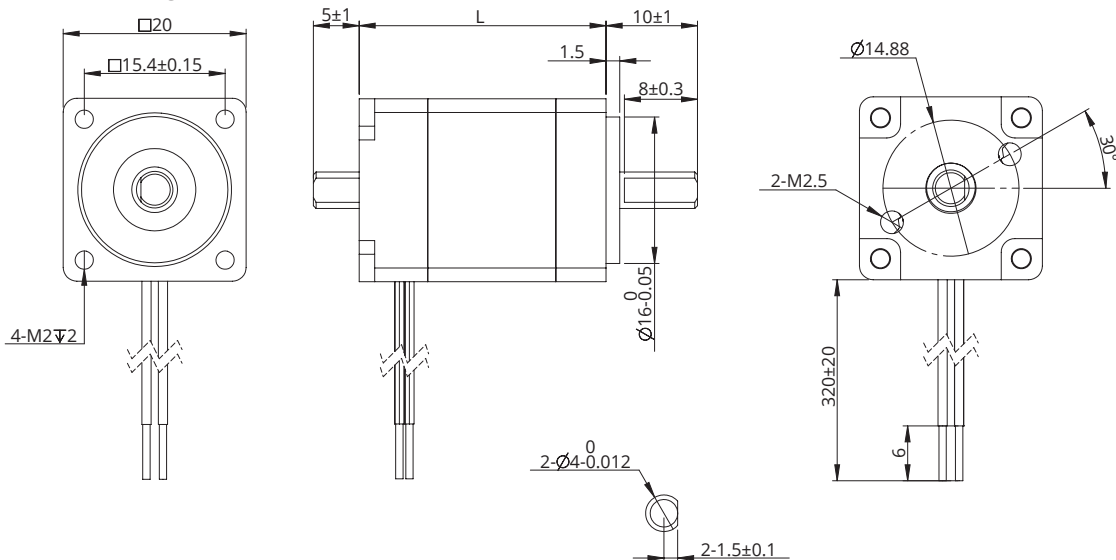

Note : All drawings are 1st Angle Projection - ISO Compliant (3D models available)

Size 8 (20mm) Series

Torque Performance Curves

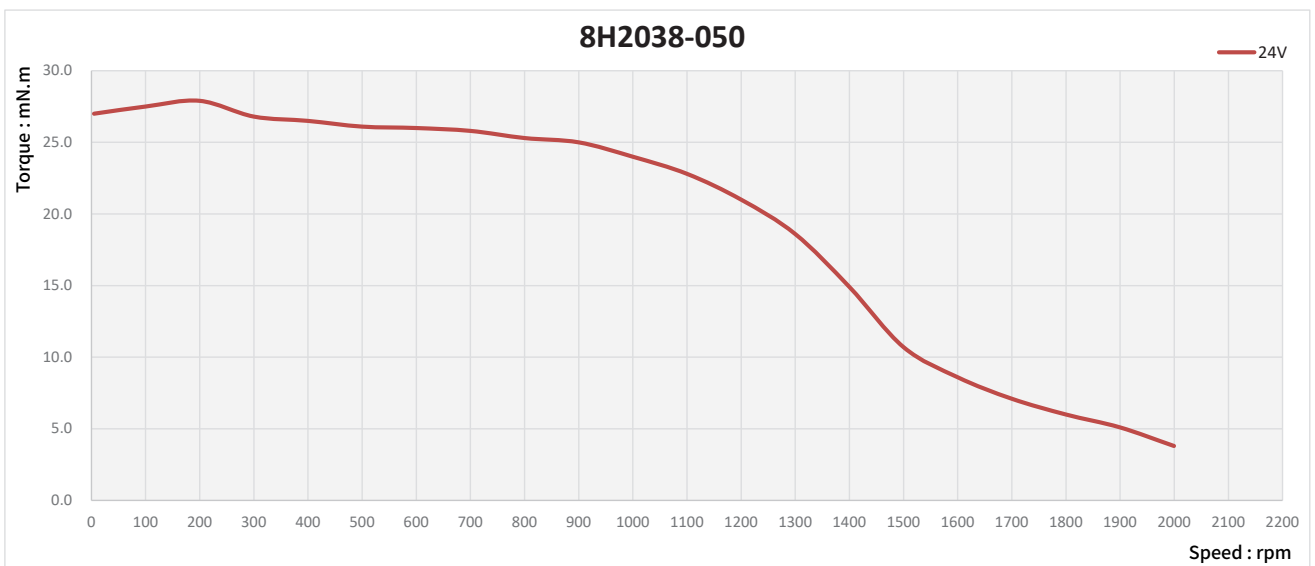
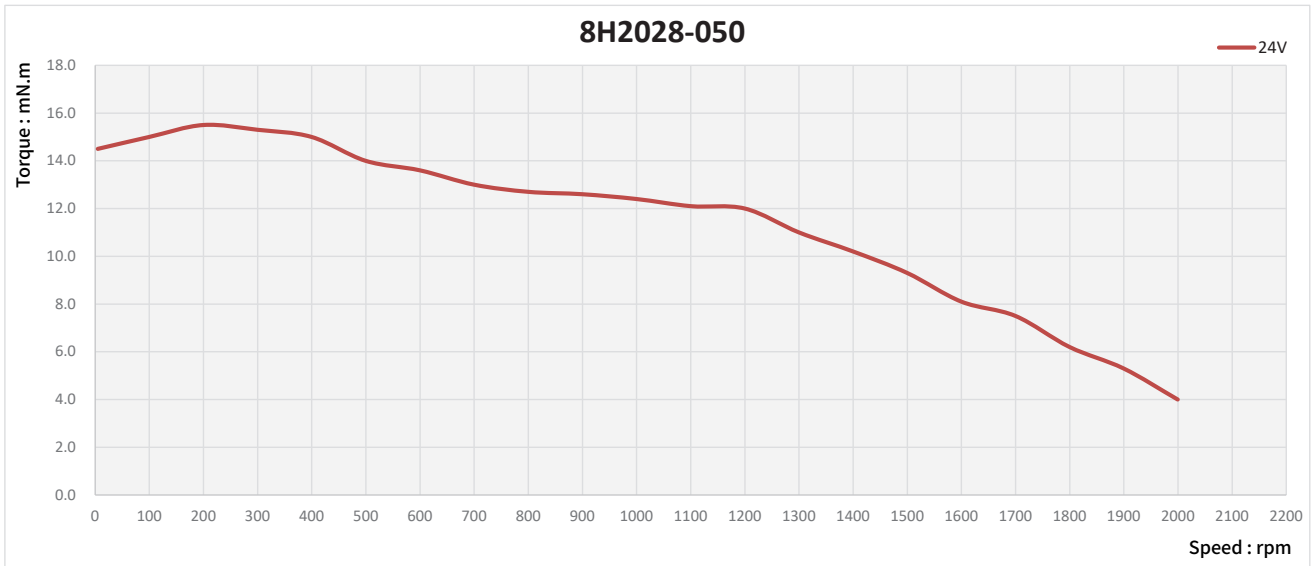

Size 11 (28mm) Series

The size 11 [28mm] Hybrid Rotary Stepper Motor has Max. 0.14N·m of holding torque. Encoders and 28mm frame planetary gearbox solutions are available. For special windings or customization, Please contact DINGS' for further information.



Parameters

General							
Accuracy	Step angle		1.8°±5%				
	Resistance		±10% / 20 C				
	Inductance		±20% / 1KHz				
Insulation class			B				
Duty type			S1				
Dielectrical strength			500 VAC / 1 KHz / 1 mA / 1 s				
Insulation resistance			100 MΩ / 500 VDC				
Permissible radial load (5mm distance from mounting surface)		Permissible radial load (10mm distance from mounting surface)		Permissible radial load (15mm distance from mounting surface)		Permissible radial load (20mm distance from mounting surface)	
50N		35N		25N		20N	
Parameter							
Type	Current (A [RMS])	Resistance (Ω)	Inductance (mH)	Holding Torque (N·m)	Rotor Inertia (g·cm ²)	Length (mm)	Mass (g)
11H2033	1	2.1	1.2	0.06	9	33.5	110
11H2045	1	4.1	3.2	0.1	13	45	200
11H2052	1	4.7	3.9	0.14	18	52	280
Material							
End bell				Aluminum alloy			
Bearing				Deep groove ball bearing			
Magnet				Sintered NdFeb			
Shaft				Stainless steel			
Wiring				UL 3265, 26AWG			

Dimensional Drawings

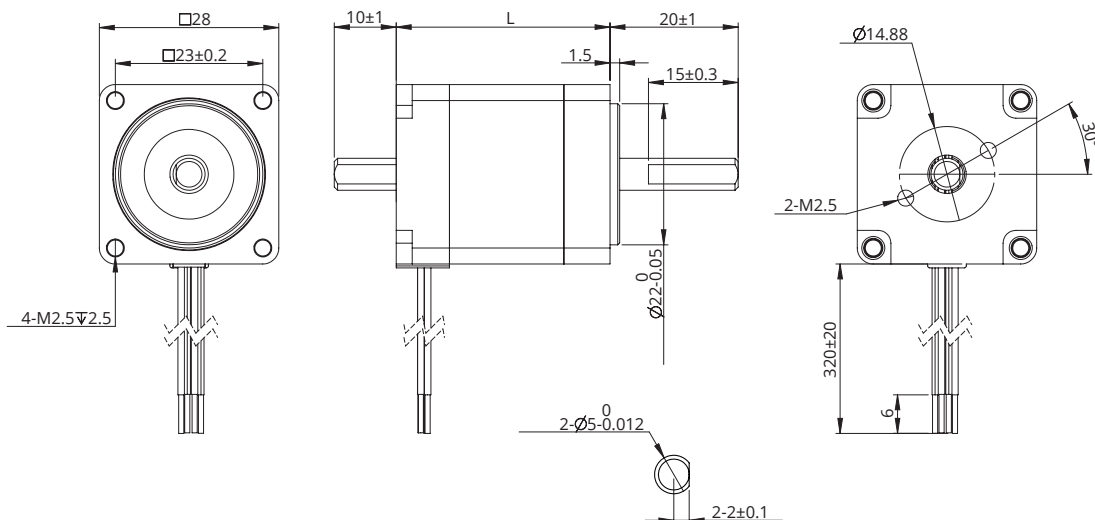

Note : All drawings are 1st Angle Projection - ISO Compliant (3D models available)

Size 11 (28mm) Series

Torque Performance Curves

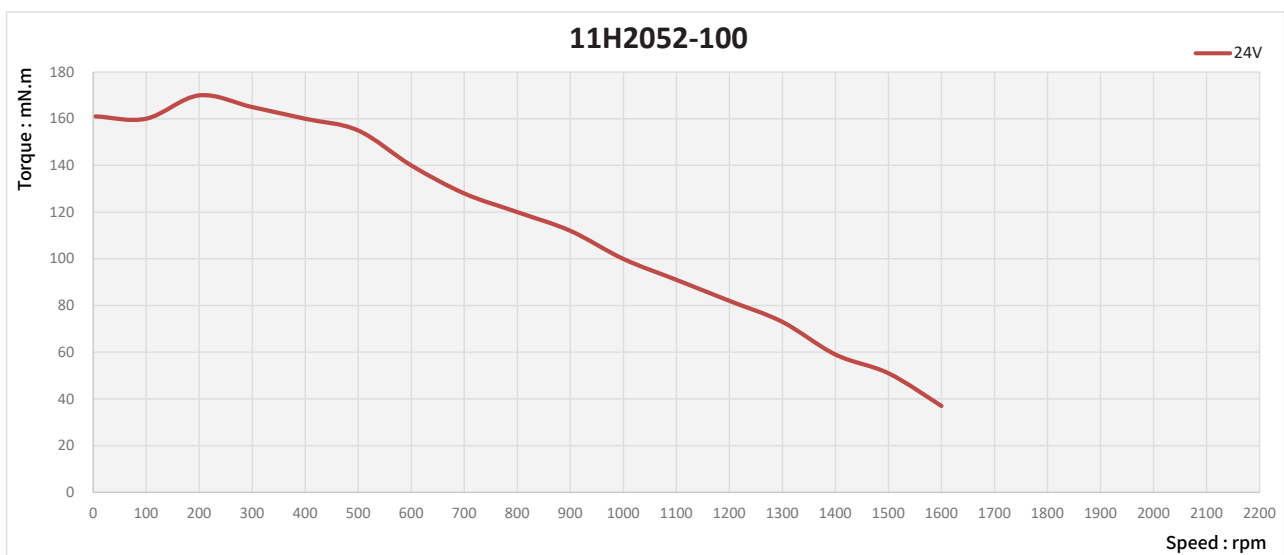
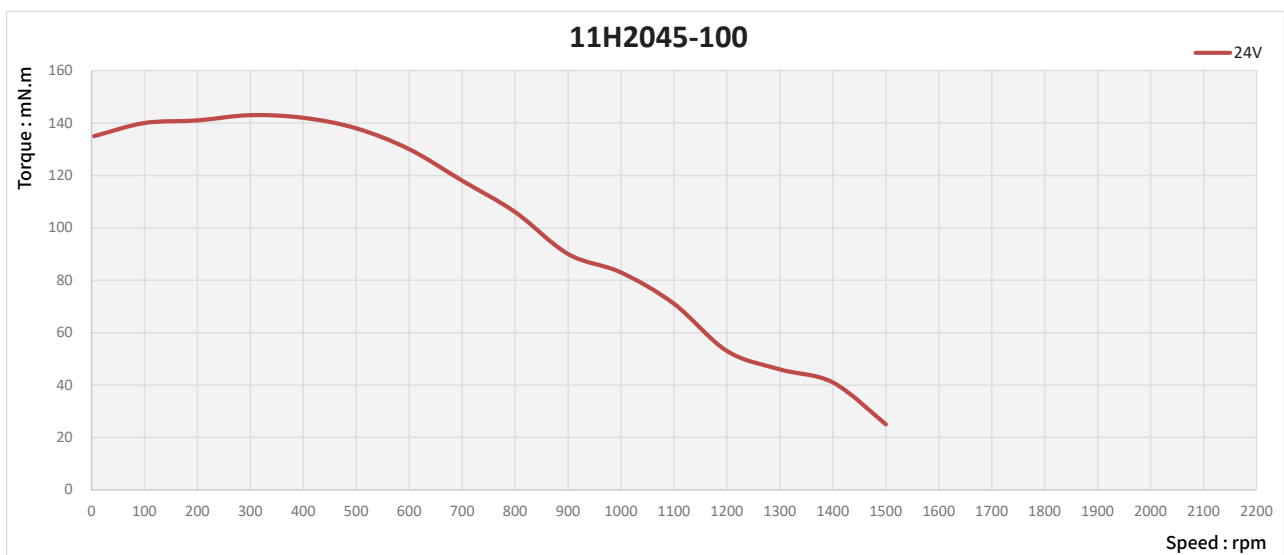
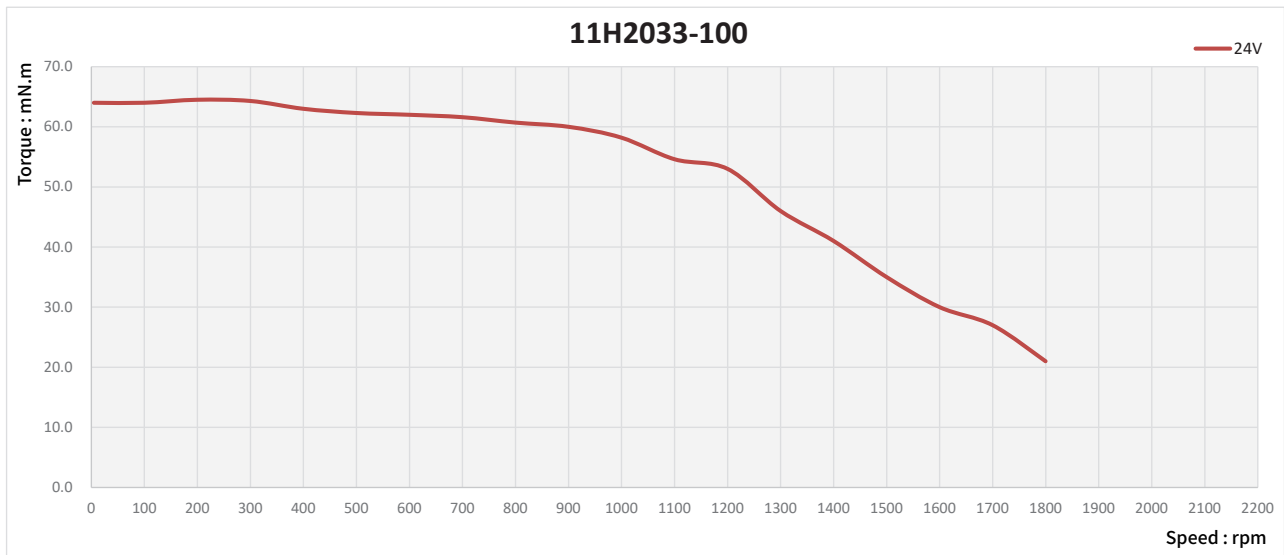

Size 14 (35mm) Series

The size 14 [35mm] Hybrid Rotary Stepper Motor has Max. 0.4N·m of holding torque. Encoders and 32mm frame planetary gearbox solutions are available. For special windings or customization, Please contact DINGS' for further information.



Parameters

General							
Accuracy	Step angle		1.8°±5%				
	Resistance		±10% / 20 C				
	Inductance		±20% / 1KHz				
Insulation class			B				
Duty type			S1				
Dielectrical strength			500 VAC / 1 KHz / 1 mA / 1 s				
Insulation resistance			100 MΩ / 500 VDC				
Permissible radial load (5mm distance from mounting surface)		Permissible radial load (10mm distance from mounting surface)		Permissible radial load (15mm distance from mounting surface)		Permissible radial load (20mm distance from mounting surface)	
50N		40N		25N		20N	
Parameter							
Type	Current (A [RMS])	Resistance (Ω)	Inductance (mH)	Holding Torque (N·m)	Rotor Inertia (g·cm ²)	Length (mm)	Mass (g)
14H2027	0.5	9.2	7.4	0.1	12	27	150
14H2037	1.5	1.65	2.1	0.2	20	37	210
14H2052	1.5	2.65	4.1	0.4	35	52	250
Material							
End bell			Aluminum alloy				
Bearing			Deep groove ball bearing				
Magnet			Sintered NdFeb				
Shaft			Stainless steel				
Wiring			UL 3265, 26AWG				

Dimensional Drawings

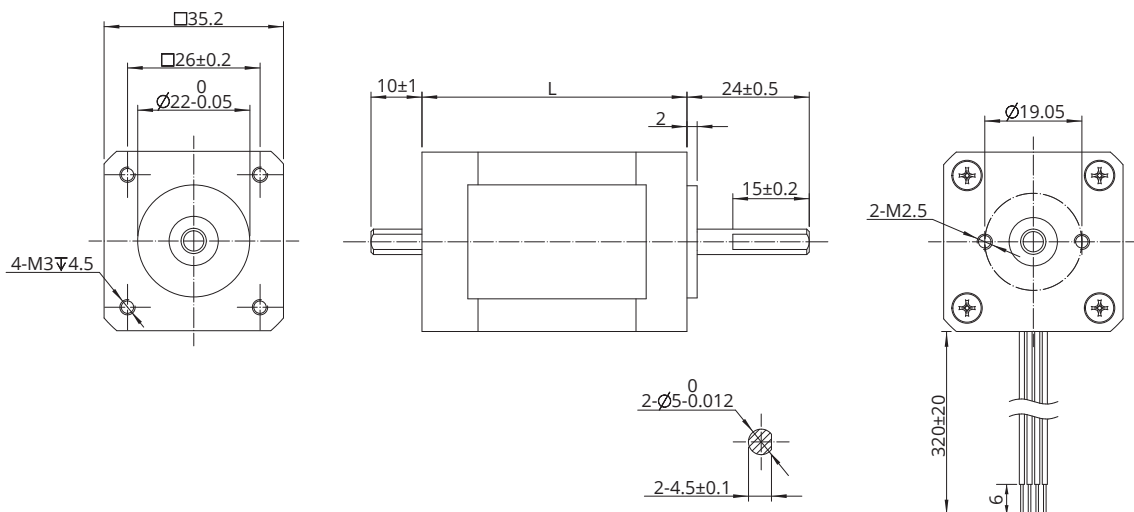

Note : All drawings are 1st Angle Projection - ISO Compliant (3D models available)

Size 14 (35mm) Series

Torque Performance Curves

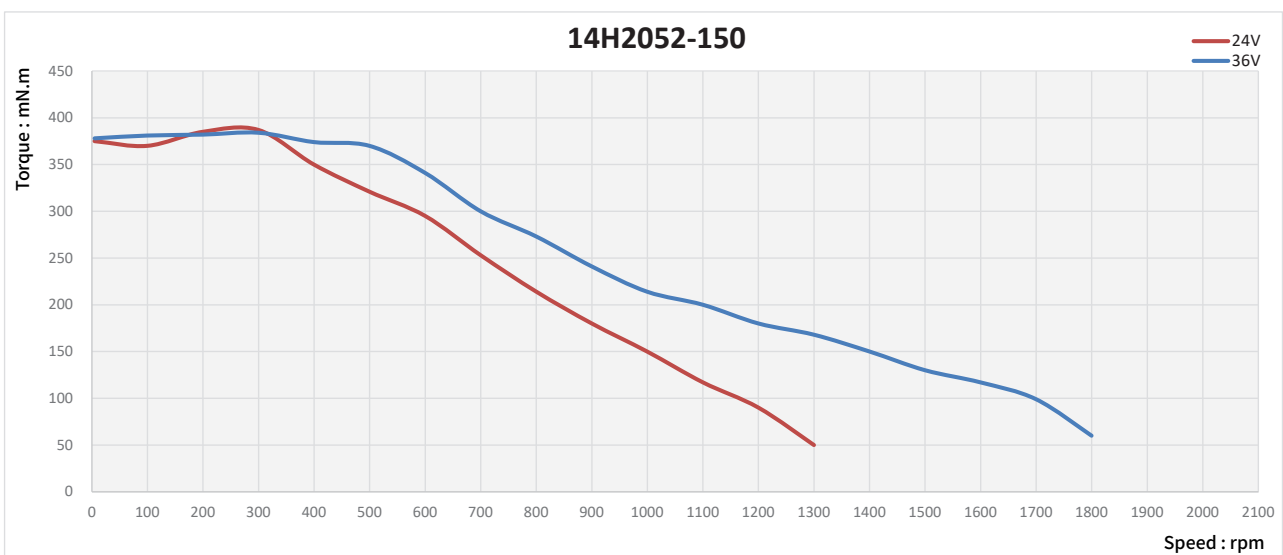
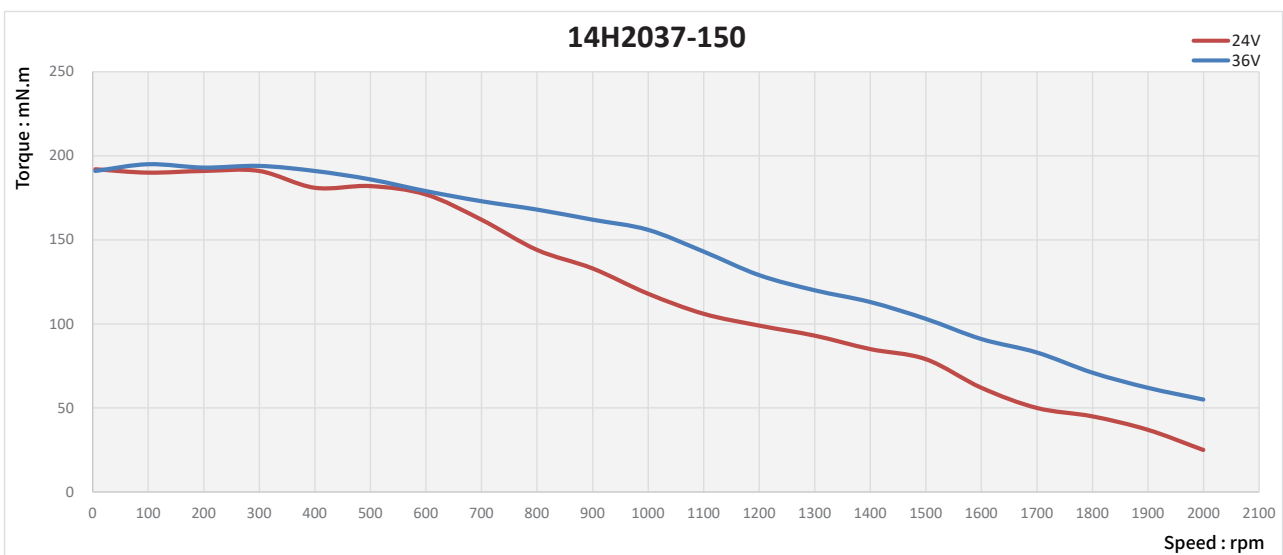
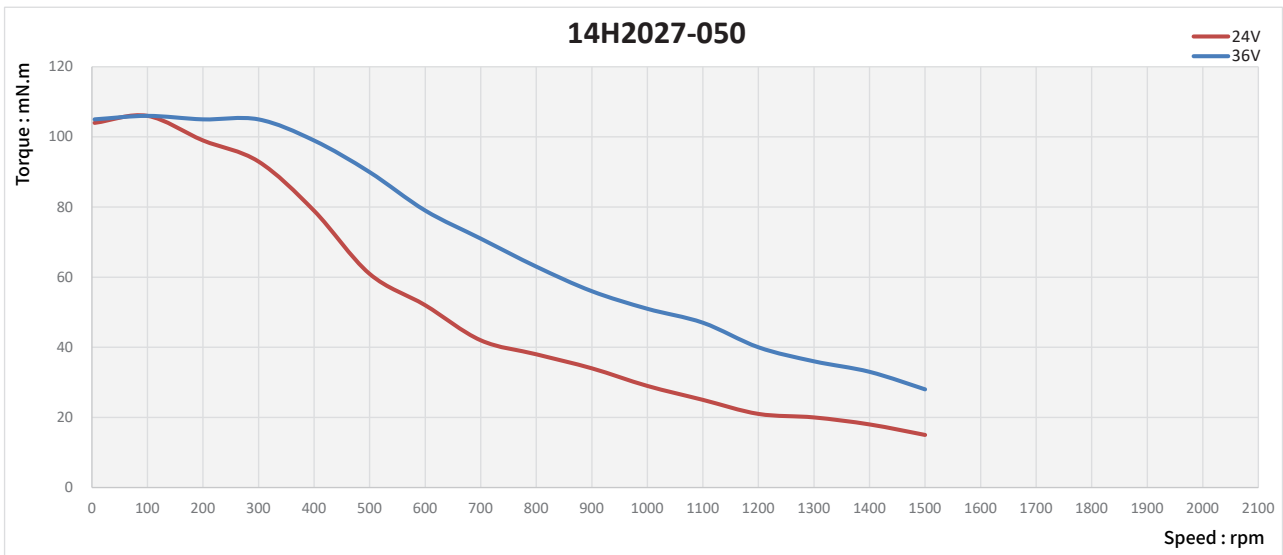

Size 17 (42mm) Series

The size 17 [42mm] Hybrid Rotary Stepper Motor has Max. 0.72N·m of holding torque. Encoders and 42mm frame planetary gearbox solutions are available. For special windings or customization, Please contact DINGS' for further information.



Parameters

General							
Accuracy	Step angle		1.8°±5%				
	Resistance		±10% / 20 C				
	Inductance		±20% / 1KHz				
Insulation class			B				
Duty type			S1				
Dielectrical strength			500 VAC / 1 KHz / 1 mA / 1 s				
Insulation resistance			100 MΩ / 500 VDC				
Permissible radial load (5mm distance from mounting surface)		Permissible radial load (10mm distance from mounting surface)		Permissible radial load (15mm distance from mounting surface)		Permissible radial load (20mm distance from mounting surface)	
50N		40N		25N		20N	
Parameter							
Type	Current (A _[RMS])	Resistance (Ω)	Inductance (mH)	Holding Torque (N·m)	Rotor Inertia (g·cm ²)	Length (mm)	Mass (g)
17H2031	1.2	1.7	2.3	0.16	23	31	200
17H2034	1.2	2.1	2.7	0.25	25	34	230
17H2041	1.2	2.4	4.7	0.4	54	41	300
17H2049	2	1.3	2	0.48	77	49	360
17H2061	2	1.7	3.6	0.72	110	61	500
Material							
End bell			Aluminum alloy				
Bearing			Deep groove ball bearing				
Magnet			Sintered NdFeb				
Shaft			Stainless steel				
Wiring			UL 3265, 26 / 24AWG				

Size 17 (42mm) Series

Dimensional Drawings

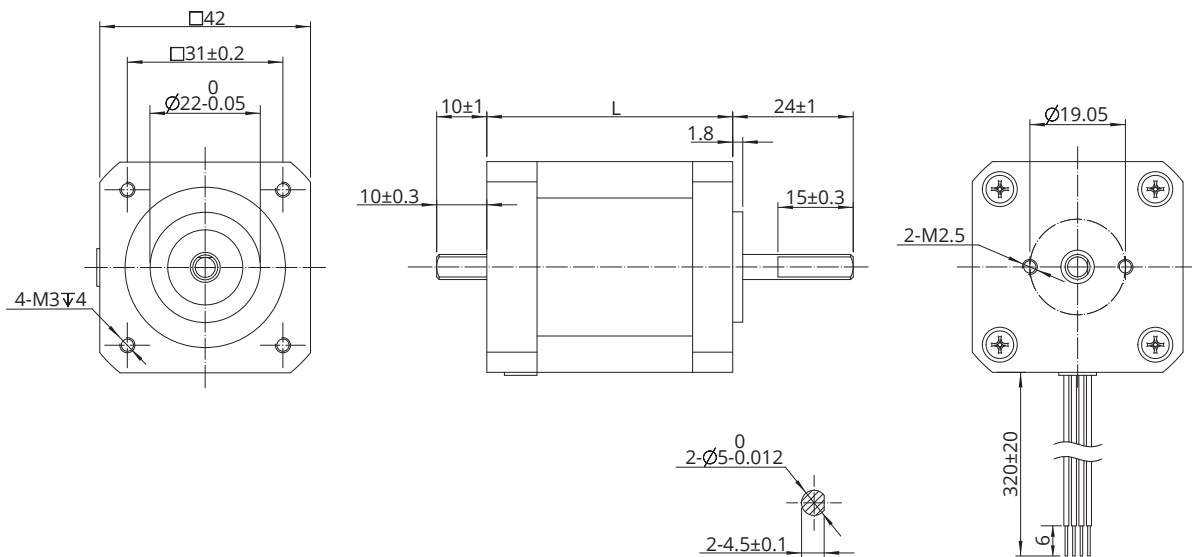

Torque Performance Curves

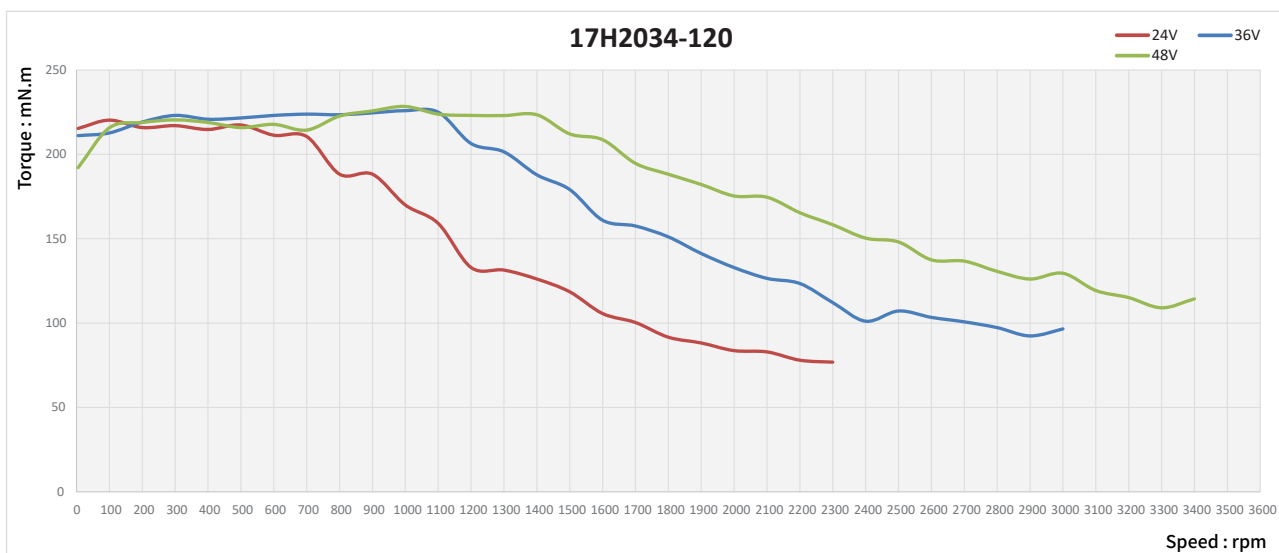
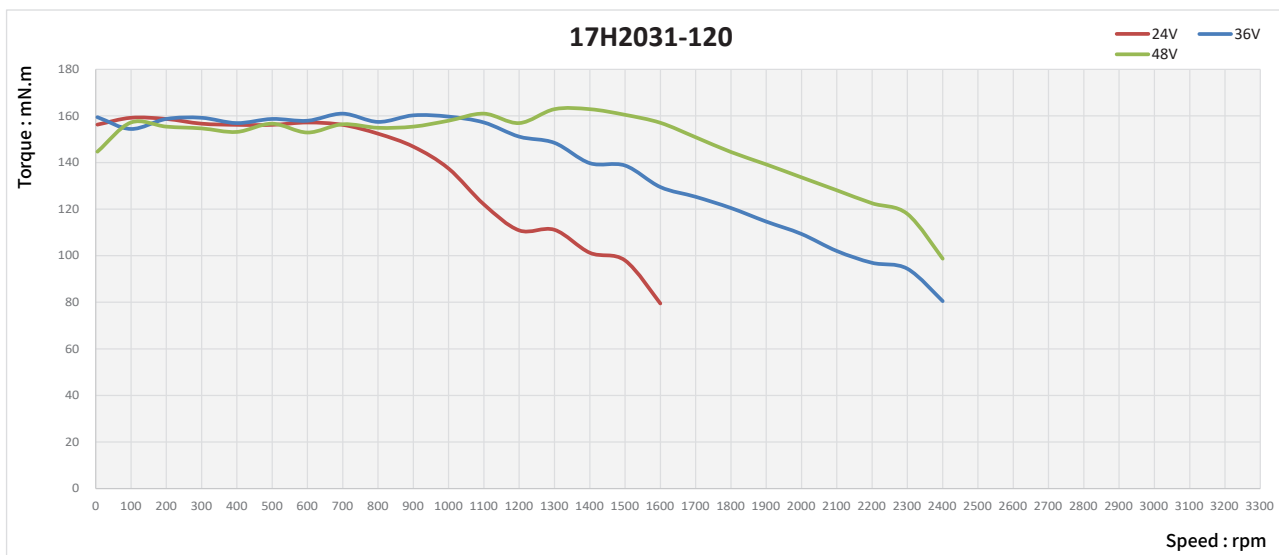

Note : All drawings are 1st Angle Projection - ISO Compliant (3D models available)

Size 17 (42mm) Series

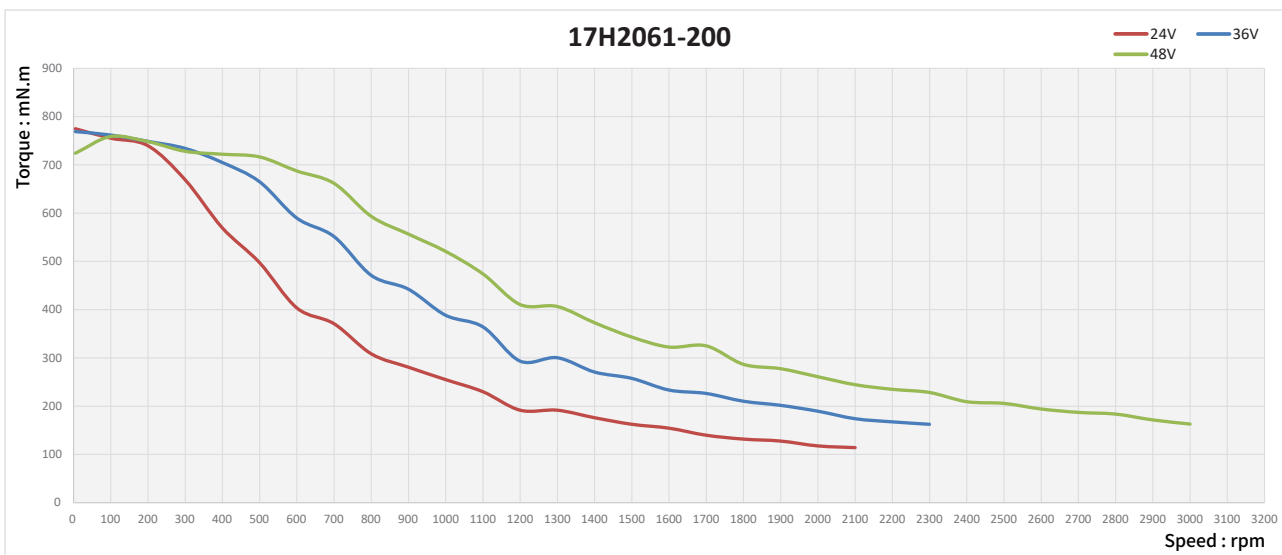
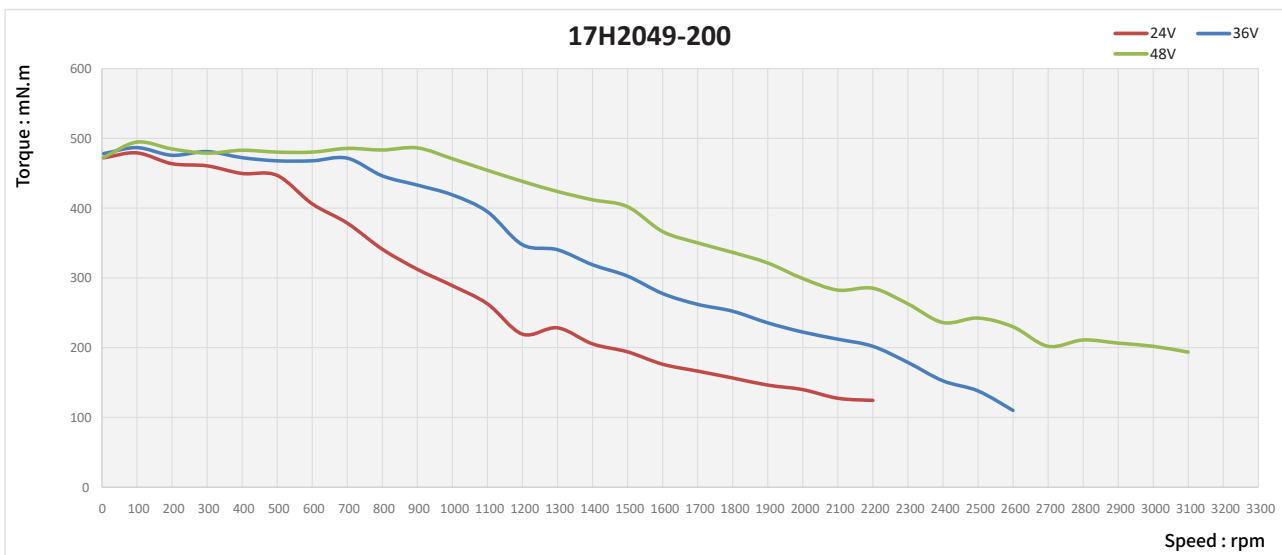
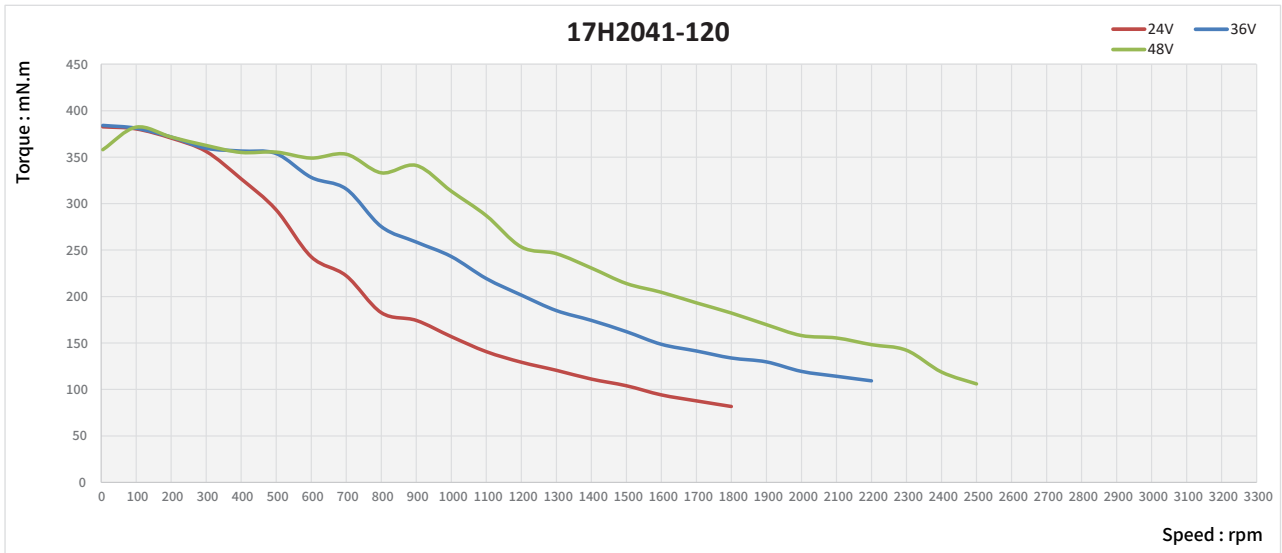

Size 23 (57mm) Series

The size 23 [57mm] Hybrid Rotary Stepper Motor has Max. 3.0N·m of holding torque. Encoders and 57mm frame planetary gearbox solutions are available. For special windings or customization, Please contact DINGS' for further information.

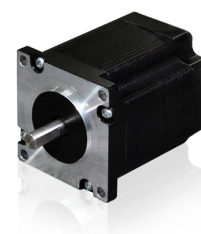

Parameters

General							
Accuracy	Step angle		1.8°±5%				
	Resistance		±10% / 20 C				
	Inductance		±20% / 1KHz				
Insulation class			B				
Duty type			S1				
Dielectrical strength			500 VAC / 1 KHz / 1 mA / 1 s				
Insulation resistance			100 MΩ / 500 VDC				
Permissible radial load (5mm distance from mounting surface)		Permissible radial load (10mm distance from mounting surface)		Permissible radial load (15mm distance from mounting surface)		Permissible radial load (20mm distance from mounting surface)	
180N		130N		100N		90N	
Parameter							
Type	Current (A _[RMS])	Resistance (Ω)	Inductance (mH)	Holding Torque (N·m)	Rotor Inertia (g·cm ²)	Length (mm)	Mass (g)
23H2042	1	4.2	9	0.6	140	42	460
23H2045	1	4.5	12	0.8	180	45	520
23H2051	2	1.5	4.4	1	240	51	640
23H2055	2	1.6	5.2	1.2	280	55	720
23H2065	3	0.9	2.7	1.6	350	65	860
23H2076	4	0.6	2.4	2	480	76	1060
23H2100	5	0.46	2.3	3	720	100	1500
Material							
End bell				Aluminum alloy			
Bearing				Deep groove ball bearing			
Magnet				Sintered NdFeb			
Shaft				Stainless steel			
Wiring				UL 3265, 22 / 20AWG			

Size 23 (57mm) Series

Dimensional Drawings

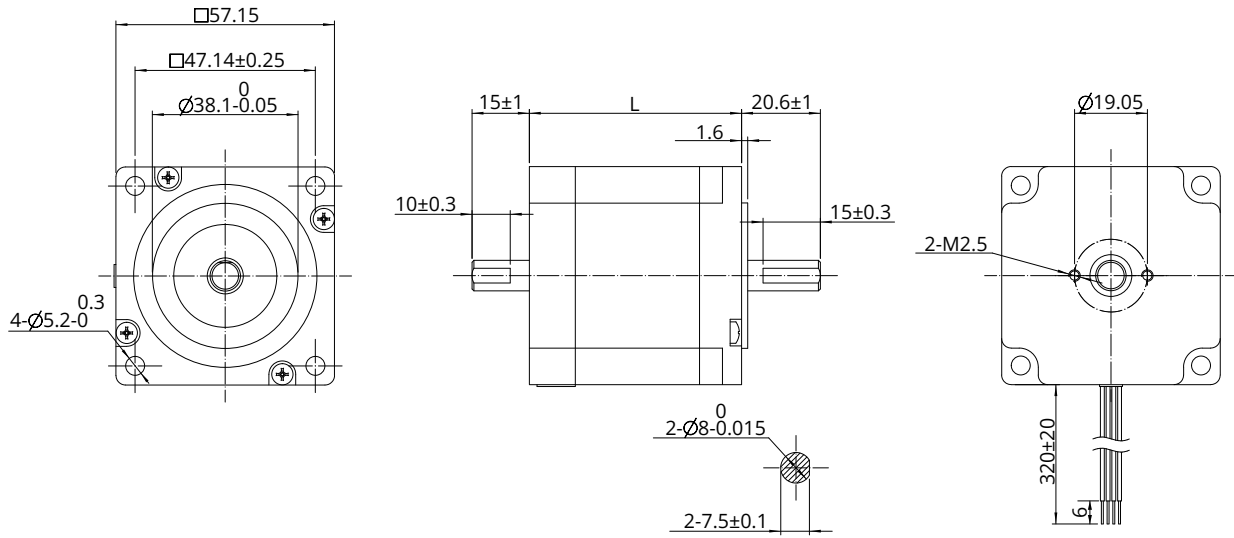

Torque Performance Curves

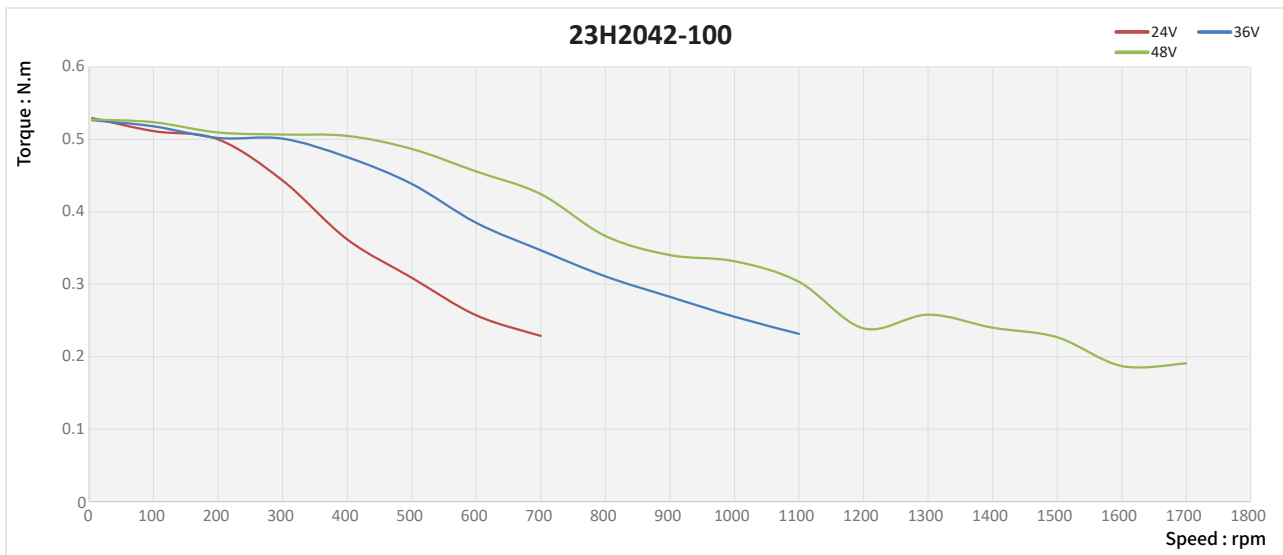

Size 23 (57mm) Series

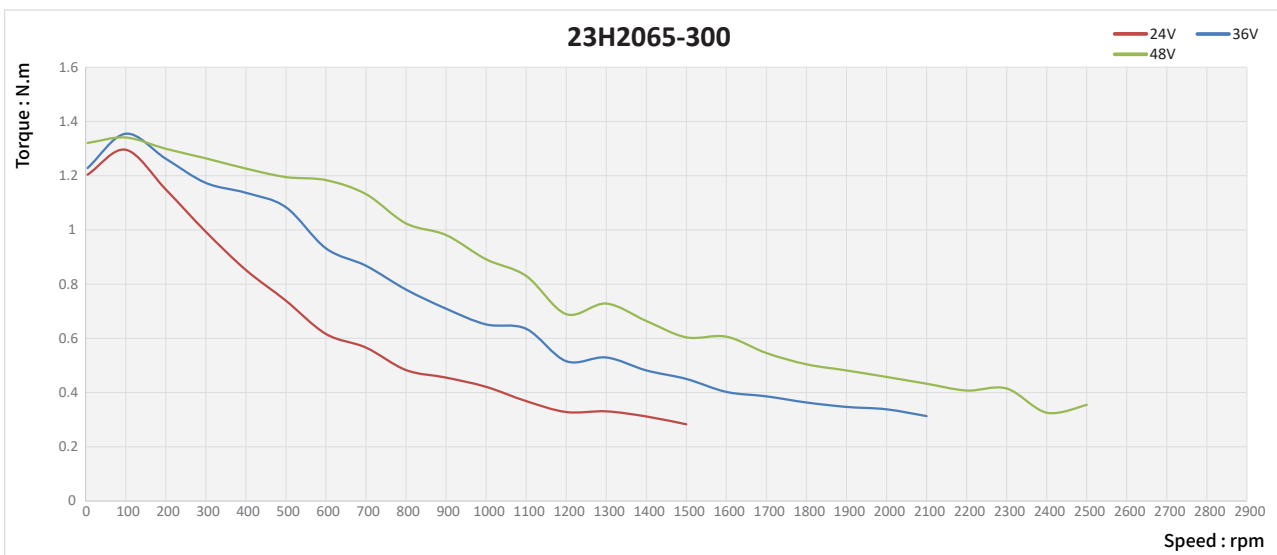
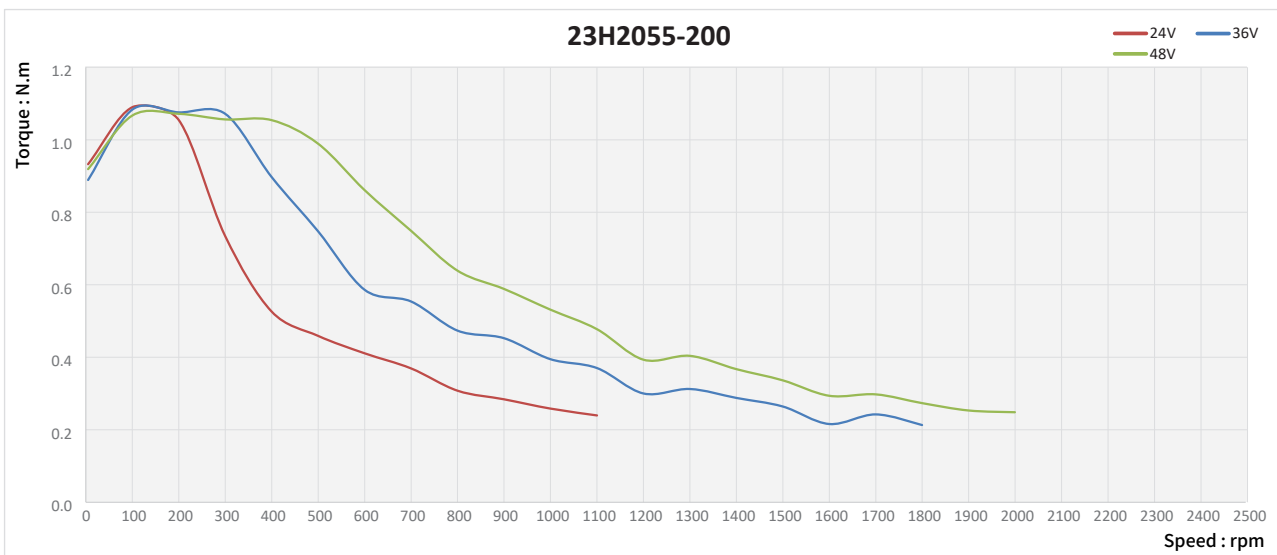

Size 23 (57mm) Series

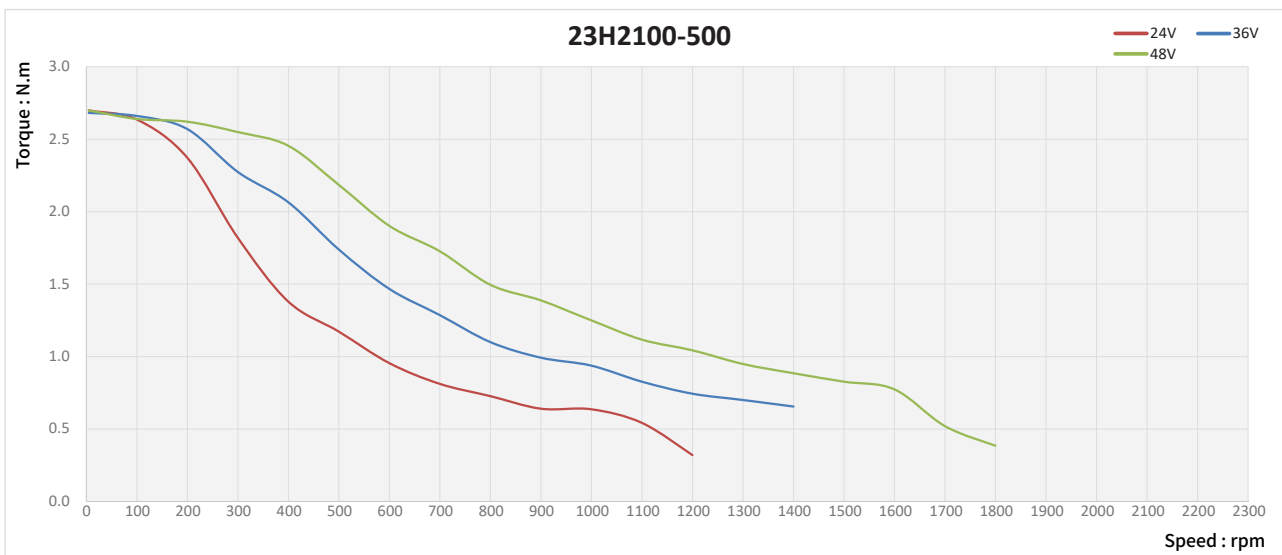
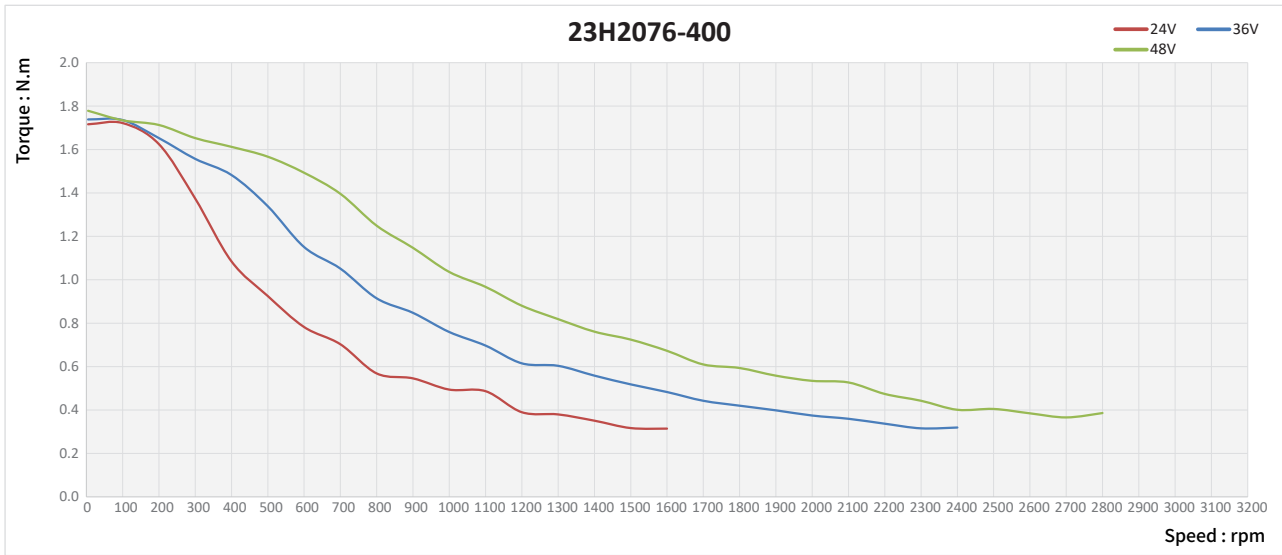

Size 24 (60mm) Series

The size 24 [60mm] Hybrid Rotary Stepper Motor has Max. 3.0N·m of holding torque. Encoders and 60mm frame planetary gearbox solutions are available. For special windings or customization, Please contact DINGS' for further information.

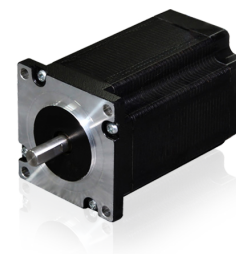

Parameters

General							
Accuracy	Step angle		1.8°±5%				
	Resistance		±10% / 20 C				
	Inductance		±20% / 1KHz				
Insulation class			B				
Duty type			S1				
Dielectrical strength			500 VAC / 1 KHz / 1 mA / 1 s				
Insulation resistance			100 MΩ / 500 VDC				
Permissible radial load (5mm distance from mounting surface)		Permissible radial load (10mm distance from mounting surface)		Permissible radial load (15mm distance from mounting surface)		Permissible radial load (20mm distance from mounting surface)	
210N		170N		140N		120N	
Parameter							
Type	Current (A _[RMS])	Resistance (Ω)	Inductance (mH)	Holding Torque (N·m)	Rotor Inertia (g·cm ²)	Length (mm)	Mass (g)
24H2047	2	1.5	3.4	1	240	47	600
24H2056	3	0.8	2.3	1.5	340	56	800
24H2068	4	0.6	1.9	2.1	490	68	1000
24H2085	5	0.4	1.8	3	690	85	1300
Material							
End bell			Aluminum alloy				
Bearing			Deep groove ball bearing				
Magnet			Sintered NdFeb				
Shaft			Stainless steel				
Wiring			UL 3265, 20 / 22AWG				

Size 24 (60mm) Series

Dimensional Drawings

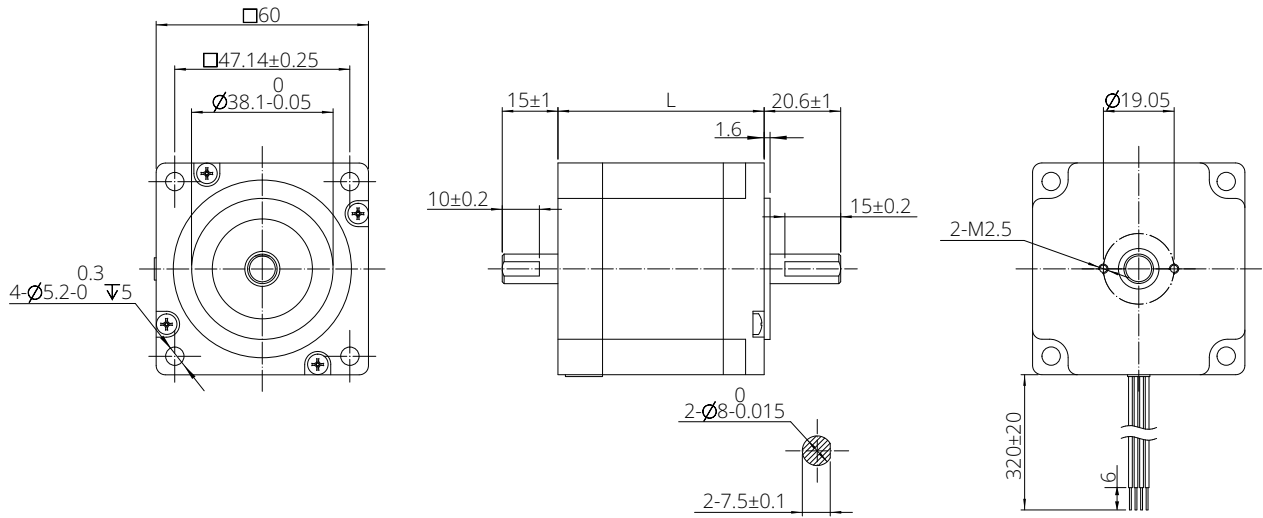

Torque Performance Curves

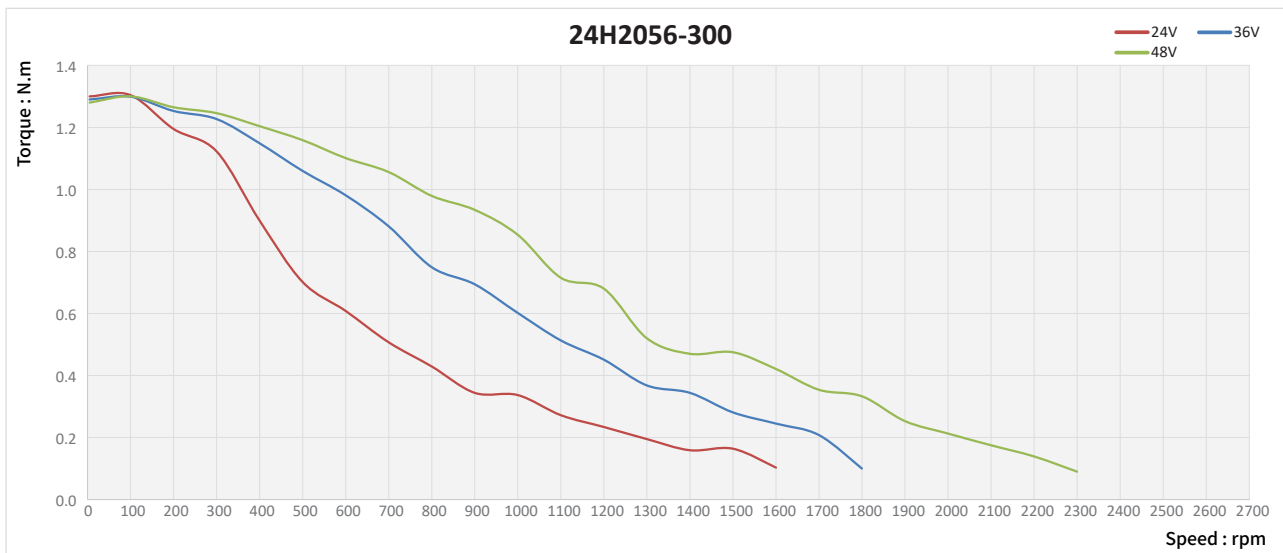
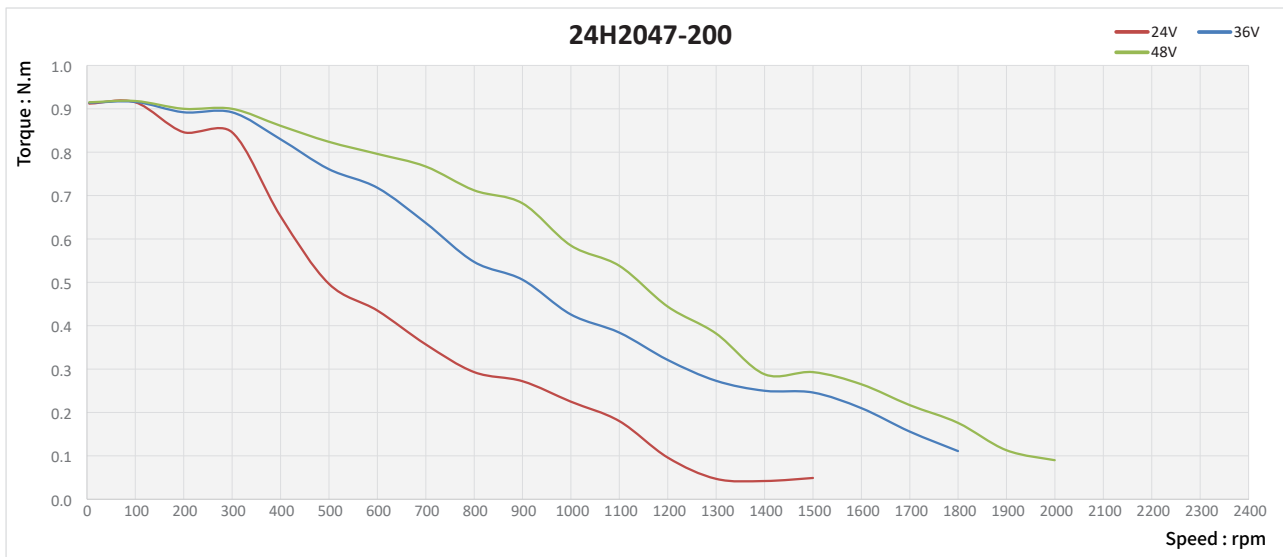

Note : All drawings are 1st Angle Projection - ISO Compliant (3D models available)

Size 24 (60mm) Series

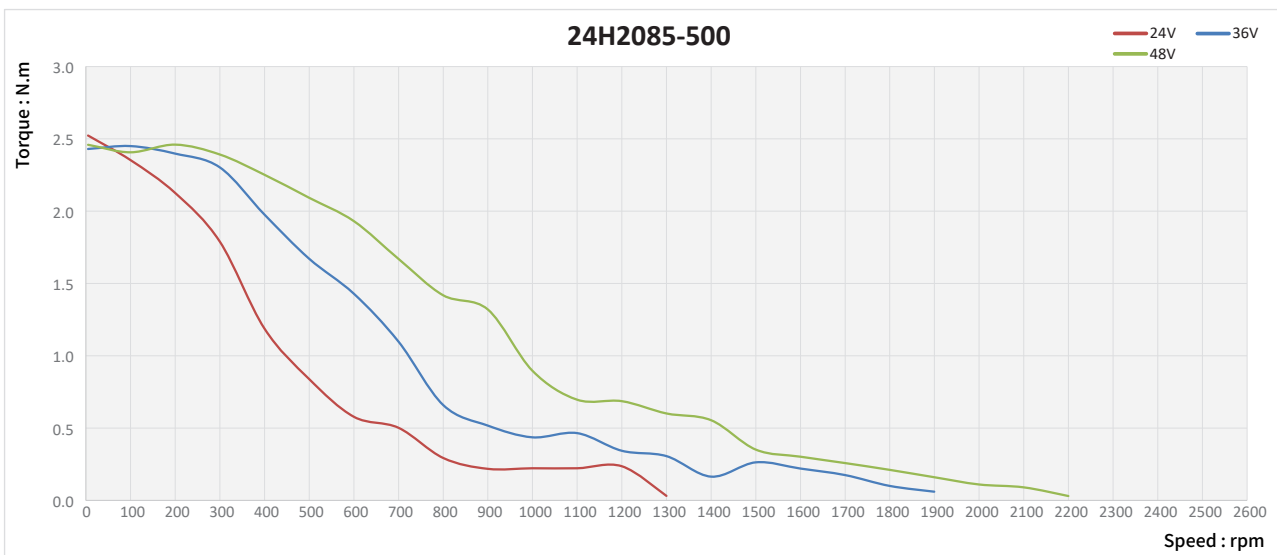
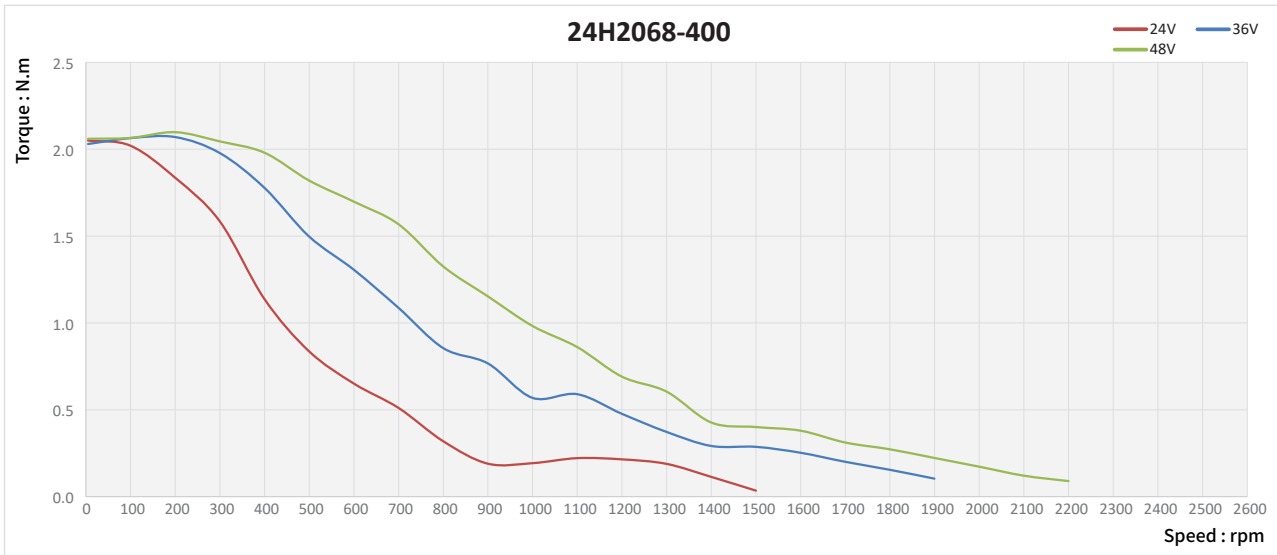

Size 34 (86mm) Series

The size 34 [86mm] Hybrid Rotary Stepper Motor has Max. 7.0N·m of holding torque. Encoders solutions are available.

For special windings or customization, Please contact DINGS' for further information.

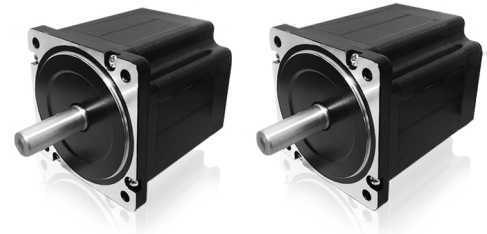

Parameters

General							
Accuracy	Step angle		1.8°±5%				
	Resistance		±10% / 20 C				
	Inductance		±20% / 1 KHz				
Insulation class			B				
Duty type			S1				
Dielectrical strength			500 VAC / 1 KHz / 1 mA / 1 s				
Insulation resistance			100 MΩ / 500 VDC				
Permissible radial load (5mm distance from mounting surface)		Permissible radial load (10mm distance from mounting surface)		Permissible radial load (15mm distance from mounting surface)		Permissible radial load (20mm distance from mounting surface)	
600N		550N		480N		390N	
Parameter							
Type	Current (A [RMS])	Resistance (Ω)	Inductance (mH)	Holding Torque (N·m)	Rotor Inertia (g·cm ²)	Length (mm)	Mass (g)
34H2060	3	1	6	3	1100	60.5	1600
34H2075	4.5	0.6	4.2	4.5	1800	75	2100
34H2098	6	0.5	4	7	2800	96.5	2900
Material							
End bell			Aluminum alloy				
Bearing			Deep groove ball bearing				
Magnet			Sintered NdFeb				
Shaft			Stainless steel				
Wiring			UL 3265, 18AWG				

Dimensional Drawings

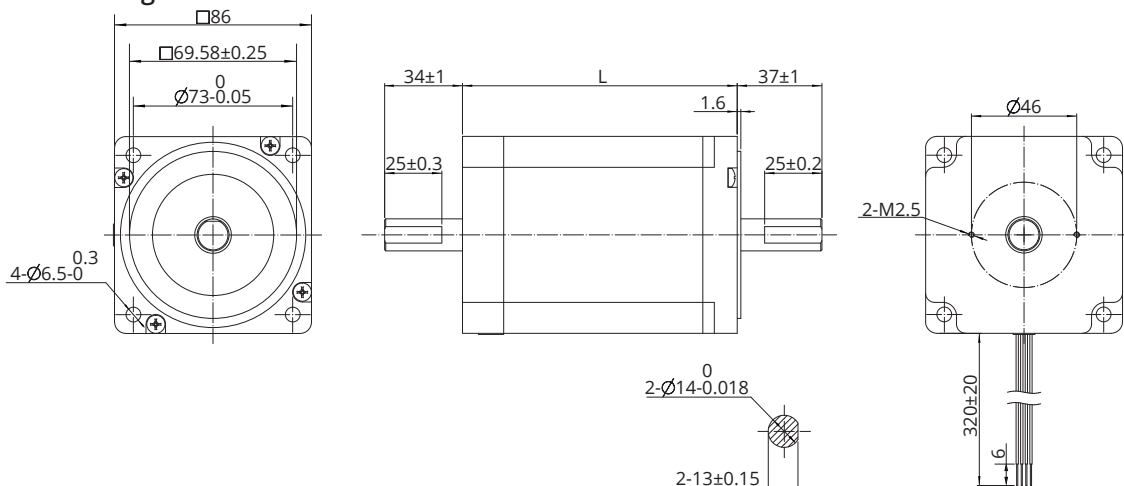

Note : All drawings are 1st Angle Projection - ISO Compliant (3D models available)

Size 34 (86mm) Series

Torque Performance Curves

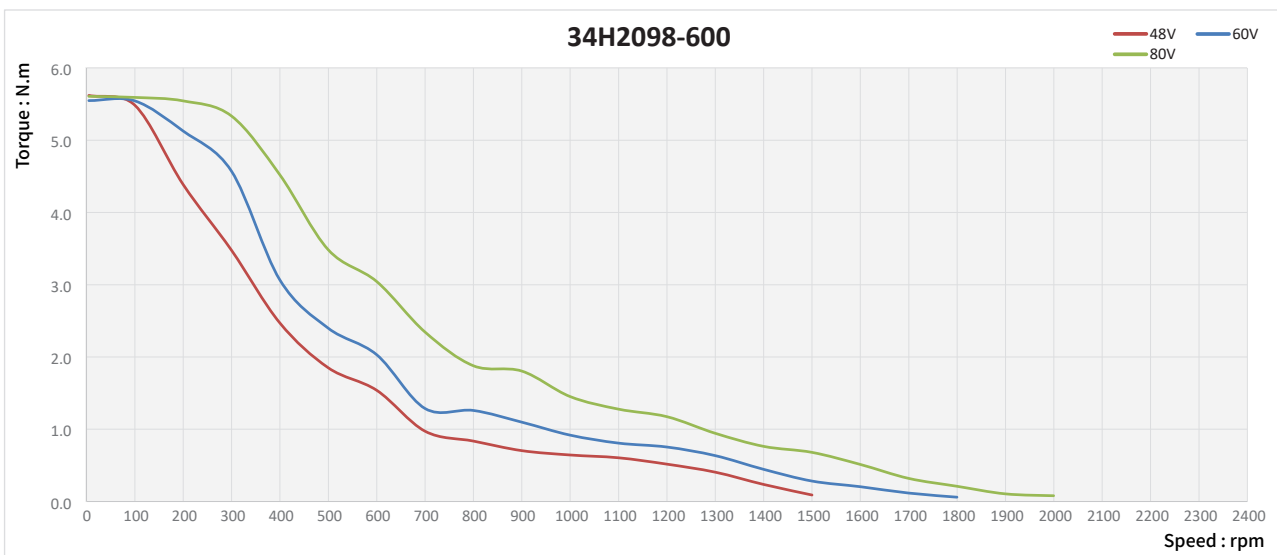
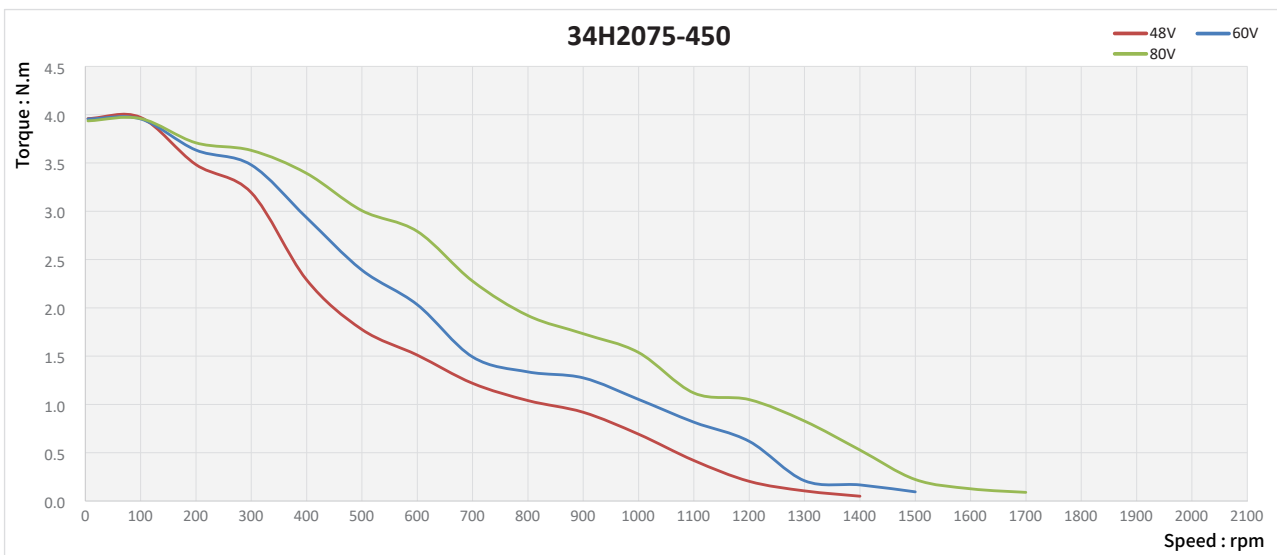
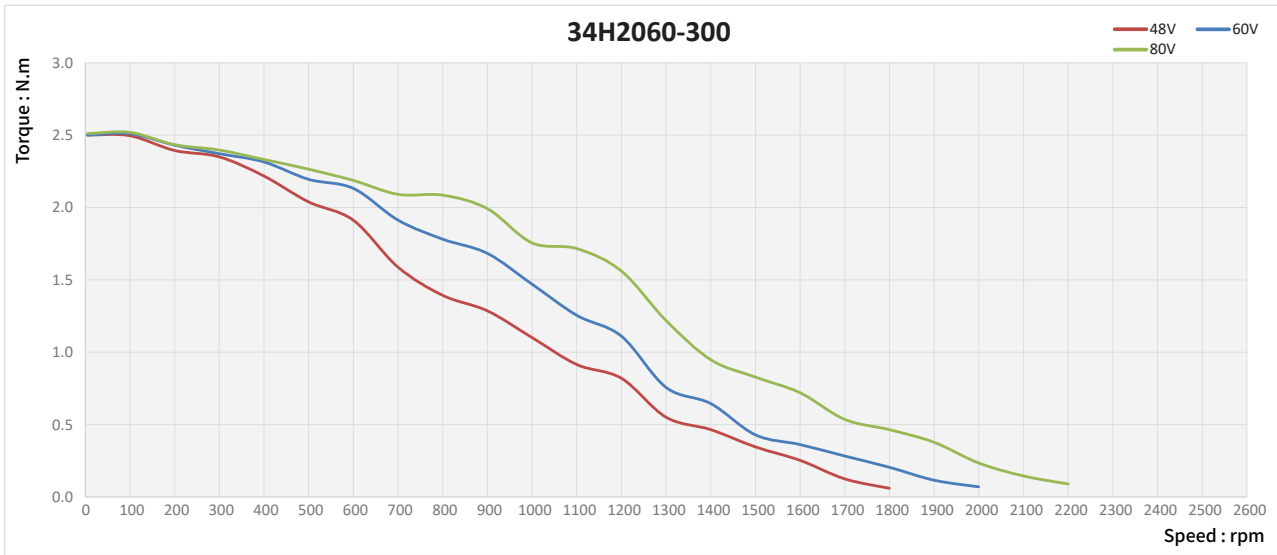

Accessories and Options

■ Planetary Gearbox

● Overview

Frame size	Ratio	Rated torque (N·m)	Limit torque (N·m)	Stages	Efficiency (%)	Length (mm)	Mass (g)	Corresponding motor
22 mm	4	0.03	0.09	1	81	16.3	29.1	20 mm
	15	0.05	0.15	2	66	16.3	30.1	
	20							
	107	0.1	0.3	3	53	19.5	36	
28 mm	3.3	0.5	1.5	1	90	21.2	87	28 mm
	4.6							
	11.2	1	3	2	81	26.9	91	
	15.5							
	21.5							
	37.7	2.5	7.5	3	73	32.7	100	
72								
32 mm	3.3	0.5	1.5	1	90	16.2	90	35 mm
	4.6							
	11.2	1	3	2	81	21.9	115	
	15.5							
	21.5							
	37.7	2.5	7.5	3	73	27.7	140	
72								
42 mm	3.7	1	3	1	90	30.6	260	42 mm
	5.2							
	13.7	2	6	2	81	41.9	350	
	19.2							
	26.9							
	50.9	5	15	3	73	53.2	440	
	71.2							
99.5								
57 mm	5	6	12	1	95	53	800	57 mm
	10							
	15	25	40	2	90	70	1100	
	20							
	25							
60 mm	5	6	12	1	95	53	900	60 mm
	10							
	15	25	40	2	90	70	1200	
	20							
	25							
86 mm	3	50	100	1	95	89	2080	86 mm
	4							
	5							
	7							
	16	80	160	2	90	112	2830	
	20							
	25							
	28							
	35							
	40							
50								

Accessories and Options

● 22mm Frame Planetary Gearbox

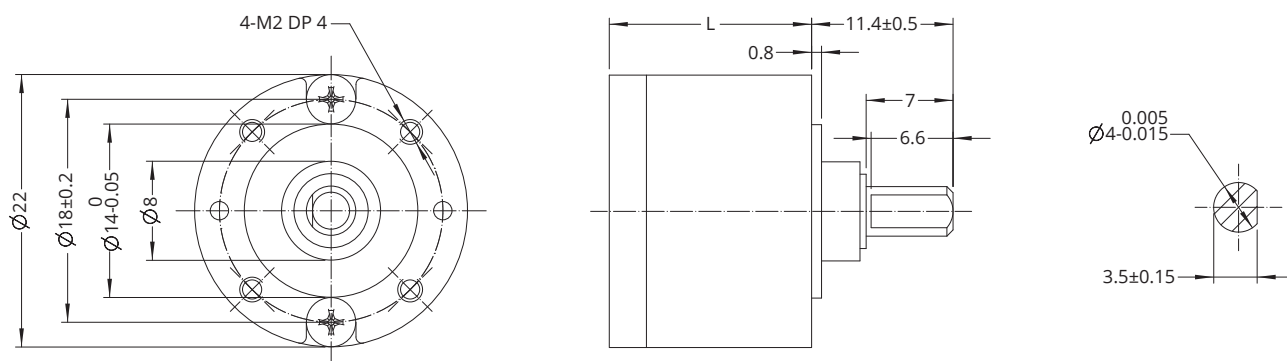

Housing material			Metal			
No load backlash			1°			
Bearing			Sleeve bearing			
Ratio	Rated torque (N·m)	Limit torque (N·m)	Stages	Efficiency (%)	Length (mm)	Mass (g)
4	0.03	0.09	1	81	16.3	29.1
15 20	0.05	0.15	2	66	16.3	30.1
107	0.1	0.3	3	53	19.5	36

● 28mm Frame Planetary Gearbox

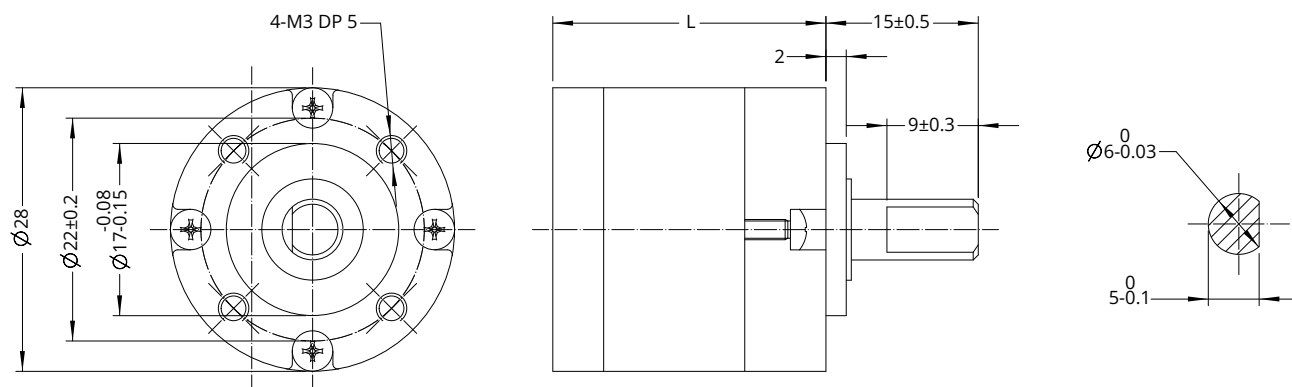

Housing material			Metal			
No load backlash			1°			
Bearing			Ball bearing			
Ratio	Rated torque (N·m)	Limit torque (N·m)	Stages	Efficiency (%)	Length (mm)	Mass (g)
3.3 4.6	0.5	1.5	1	90	21.2	87
11.2 15.5 21.5	1	3	2	81	26.9	91
37.7 72	2.5	7.5	3	73	32.7	100

Accessories and Options

● 32mm Frame Planetary Gearbox

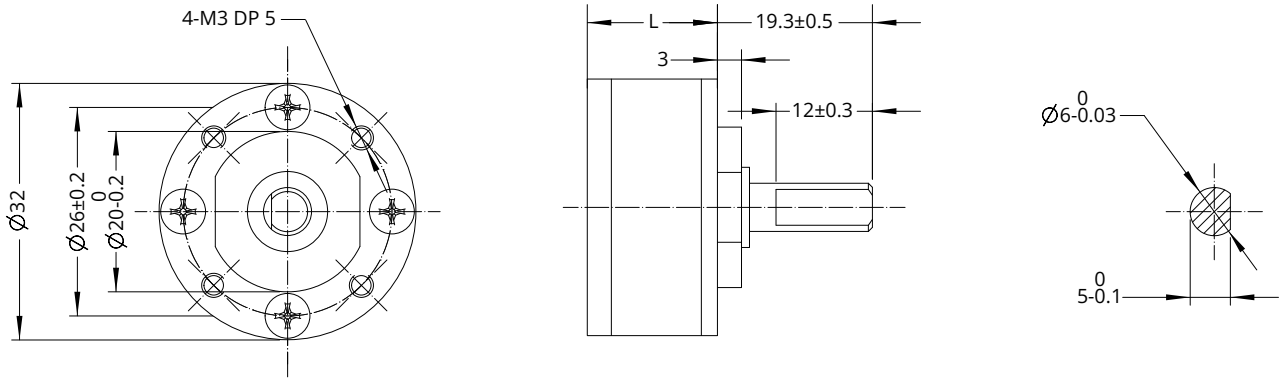

Housing material			Metal			
No load backlash			1°			
Bearing			Ball bearing			
Ratio	Rated torque (N·m)	Limit torque (N·m)	Stages	Efficiency (%)	Length (mm)	Mass (g)
3.3 4.6	0.5	1.5	1	90	16.2	90
11.2 15.5 21.5	1	3	2	81	21.9	115
37.7 72	2.5	7.5	3	73	27.7	140

● 42mm Frame Planetary Gearbox

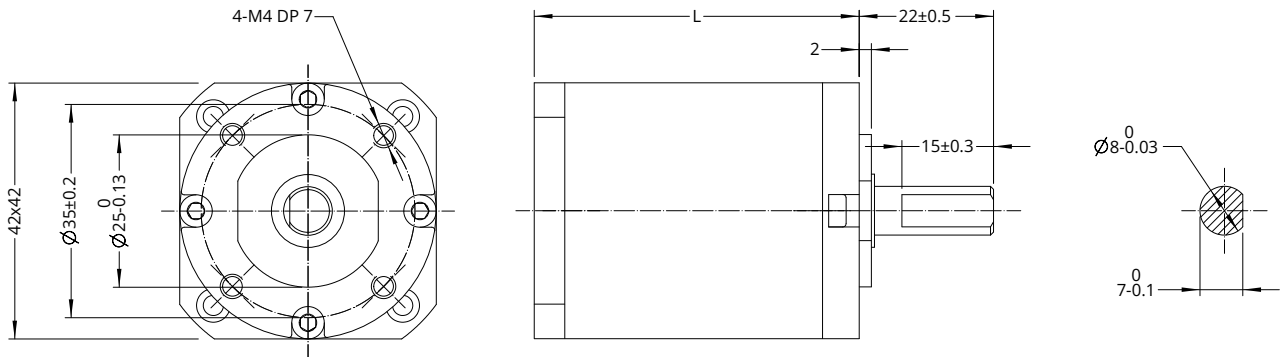

Housing material			Metal			
No load backlash			1.2°			
Bearing			Ball bearing			
Ratio	Rated torque (N·m)	Limit torque (N·m)	Stages	Efficiency (%)	Length (mm)	Mass (g)
3.7 5.2	1	3	1	90	30.6	260
13.7 19.2 26.9	2	6	2	81	41.9	350
50.9 71.2 99.5	5	15	3	73	53.2	440

Accessories and Options

● 57mm Frame Planetary Gearbox

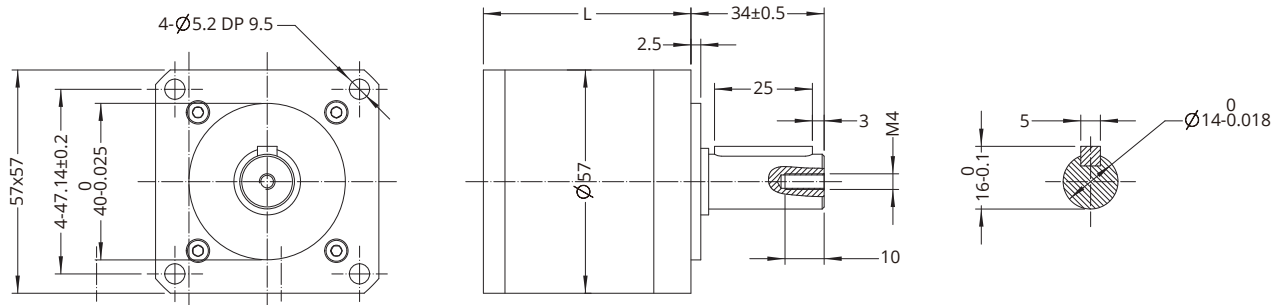

Housing material			Metal			
No load backlash			First stage 15 arcmin, second stage 25 arcmin			
Bearing			Ball bearing			
Ratio	Rated torque (N·m)	Limit torque (N·m)	Stages	Efficiency (%)	Length (mm)	Mass (g)
5 10	6	12	1	95	53	800
15 20 25	25	40	2	90	70	1100

● 60mm Frame Planetary Gearbox

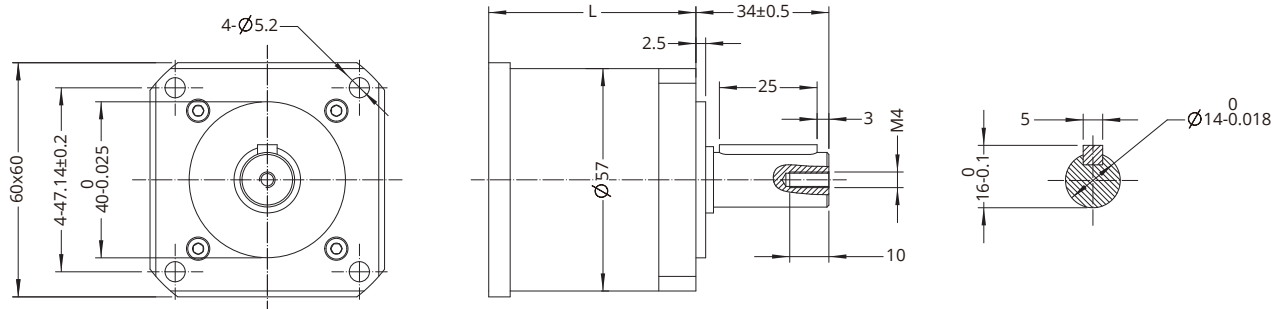

Housing material			Metal			
No load backlash			First stage 15 arcmin, second stage 25 arcmin			
Bearing			Ball bearing			
Ratio	Rated torque (N·m)	Limit torque (N·m)	Stages	Efficiency (%)	Length (mm)	Mass (g)
5 10	6	12	1	95	53	900
15 20 25	25	40	2	90	70	1200

Accessories and Options

● 86mm Frame Planetary Gearbox

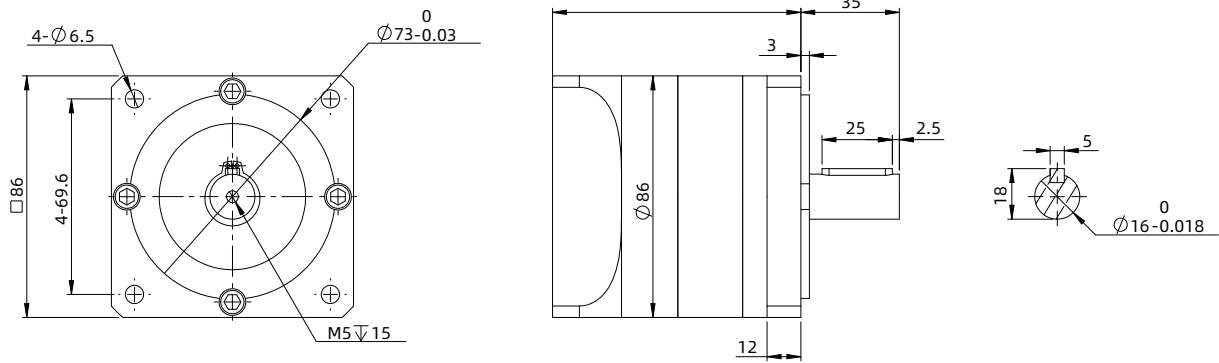

Housing material			Metal			
No load backlash			First stage 15 arcmin, second stage 25 arcmin			
Bearing			Ball bearing			
Ratio	Rated torque (N·m)	Peak torque (N·m)	Stages	Efficiency (%)	Length (mm)	Mass (g)
3 4 5 7	50	100	1	95	89	2080
16 20 25 28 35 40 50	80	160	2	90	112	2830

Accessories and Options

Encoder

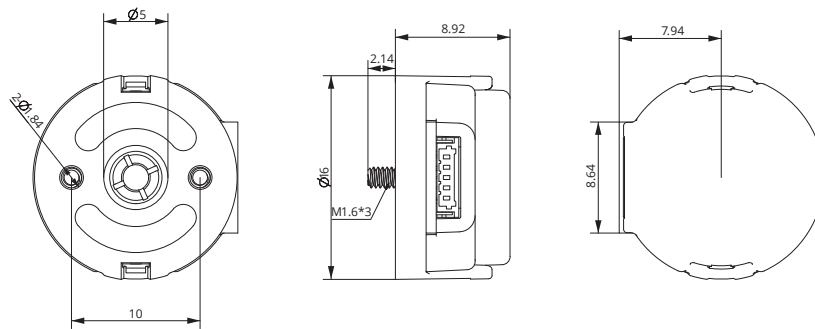

EK 6 Encoder

● EK 6 Encoder (Used for size 6 motors) * No Index

Resolution (CPR)	250	256	500	512	1000	1024	2000	2048	4000	4096
Single ended output	0	1	2	3	4	5	6	7	8	9

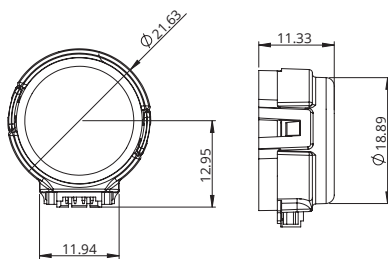

EK 1 Encoder - single ended output

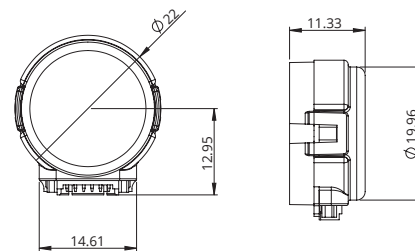

EK 1 Encoder - differential output

● EK 1 Encoder (Used for size 8, 11, 14, 17 motors) * No Index

Resolution (CPR)	100	108	120	125	128	200	250	256	300	360	400	500	1000	512	720	800
Single ended output	0	1	2	3	4	5	6	7	8	9	10	11	12	13	14	15
Differential output	A	B	C	D	E	F	G	H	I	J	K	L	M	N	O	P

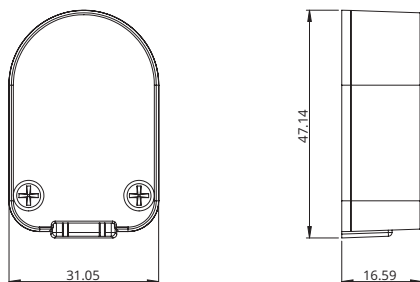

EK 2 Encoder - single ended output

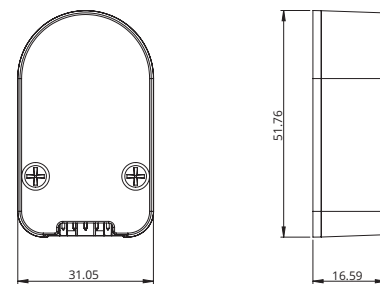

EK 2 Encoder - differential output

● EK 2 Encoder (Used for size 14, 17, 23, 24 motors)

Resolution (CPR)	50	100	192	200	250	256	360	400	500	720	900	1000	1250	2000	2500	4000	5000
Single ended output	0	1	2	3	4	5	6	7	8	9	10	11	12				
Differential output	A	B	C	D	E	F	G	H	I	J	K	L	M	N	O	P	Q

Accessories and Options

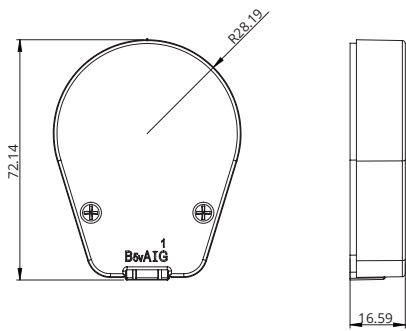

EK 3 Encoder - single ended output

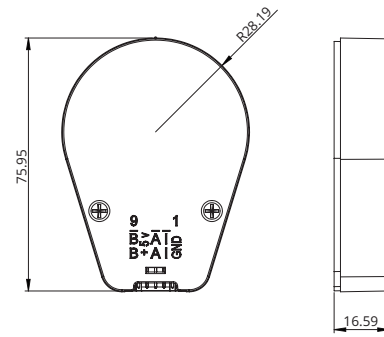

EK 3 Encoder - differential output

- EK 3 Encoder (Used for size 23, 24, 34 motors)

Resolution (CPR)	64	100	200	500	1000	1800	2000	2500	3600	4000	5000	7200	8000	10000
Single ended output	0	1	2	3	4	5	6	7	8					
Differential output		A	B	C	D	E	F	G	H	I	J	K	L	M

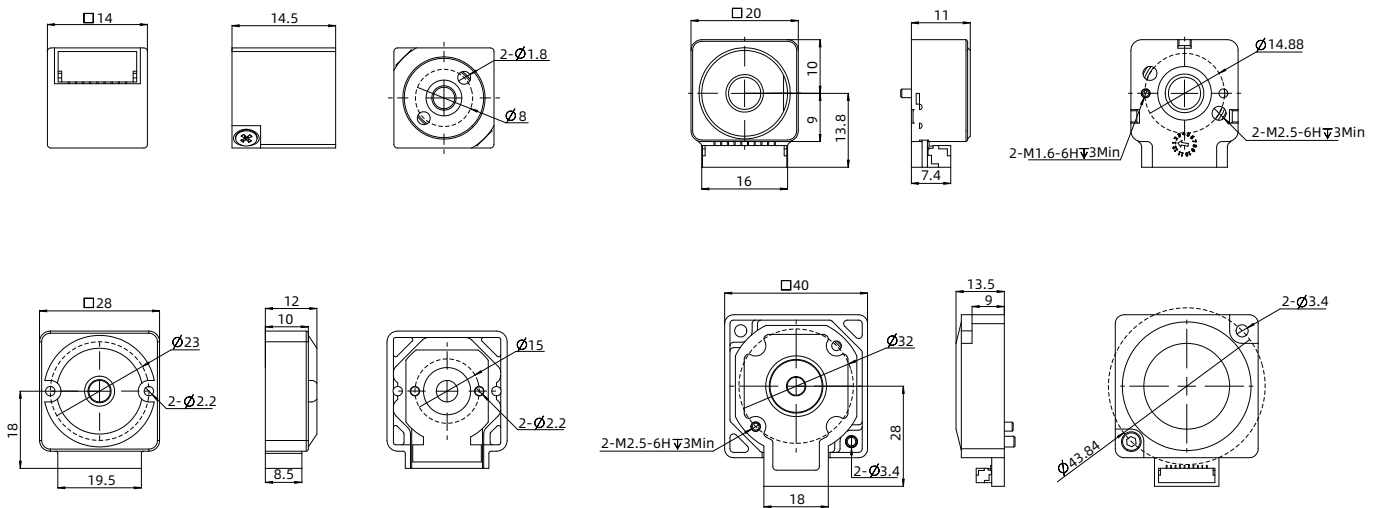

- EK 7 Encoder (Used for size 6, 8, 11, 14, 17, 23, 24 External, Non-Captive motors)

Resolution (CPR)	-	-	-	1000	-	-	2000	-	-	-
Single ended output	0	1	2	3	4	5	6	7	8	9
Differential output	A	B	C	D	E	F	G	H	I	J

DINGS'

Precision Motion Specialist

Headquarter , CHINA

Jiangsu DINGS' Intelligent Control Technology Co., LTD

No. 2850 Luheng Road, Changzhou Economic Development Zone, Jiangsu Province, China

Phone : +86-519-85177826

Fax : +86-519-85177807

E-mail : info@dingsmotion.com

www.dingsmotion.com

Shenzhen Office

Room 1105, Block C, CIMC industry demonstration park, Qiaoming Road, Guangming district, Shenzhen City

E-mail : info@dingsmotion.com

International Office

DINGS' Motion USA

355 Cochrane Circle Morgan Hill, CA 95037

Phone : +1-408-612-4970

E-mail : sales@dingsmotionusa.com

www.dingsmotionusa.com

DINGS' Motion Europe

4 Avenue du Grand Trémoutier 44120 - Vertou - France

Phone : +33-(0)6-41-37-80-07

E-mail : sebastien@dingsmotion.com

<http://fr.dingsmotion.com>

DINGS' KOREA Co., Ltd

C-702, 158, Haneulmaeul-ro, Ilsandong-gu, Goyang-si, Gyeonggi-do, Republic of Korea

Phone : +82-31-994-0755

Fax : +82-70-4325-0755

E-mail : daniel@dingsmotion.com

www.dingsmotion.kr

DINGS' JAPAN

101, 2-27-18, Nishi-kojiya, Ota-ku, Tokyo 144-0034 JAPAN

Phone : +81-3-6811-1335

E-mail : tsukahara@dingsmotion.com

www.dingsmotion.com

■ This catalog is the sole property of DINGS' and without the written authorization of DINGS', any copy or forwarding is prohibited.

■ DINGS' reserves the right to make changes without further notification to any products herein to improve the reliability, function or design.

■ DINGS' reserves the final interpretation.